



**STAMPI**

SEMIFREDDO E COTTURA

**MOULDS**

FOR SEMIFREDDO AND BAKING

# STAMPI IN PLASTICA PER SEMIFREDDO REUSABLE SEMIFREDDO MOULDS



Martellato offre un'ampia gamma di stampi semifreddo di varie dimensioni e dalle più svariate forme. Modelli dal design moderno che garantiscono un raffinato risultato e conferiscono al dessert un tocco di assoluta originalità. Lo stampo Martellato è realizzato in materiale plastico resistente ma allo stesso tempo sufficientemente flessibile per permettere una facile estrazione. Per garantire un buon risultato Martellato consiglia di scuotere lo stampo, una volta riempito, per compattarne il contenuto ed eliminare la possibile formazione di bolle d'aria. Congelare il semifreddo, in abbattitore o freezer, fino a -20°C al cuore. Conf. 2 pezzi, stesso modello, formato piccolo e grande.

Martellato offers a wide range of soft ice-cream moulds of various sizes and shapes. Modern design models that provide a stylish result and give the dessert a touch of absolute originality. Martellato moulds are made of durable plastic, but at the same time, sufficiently flexible to allow an easy extraction. To ensure a good result Martellato recommends to shake the mould, once filled, to tamp down and eliminate the possible formation of air bubbles. Freeze the semifreddo in the blast chiller or freezer, reaching -20°C in the heart of the cake. Pack 2 pcs, big and small size of the same shape.

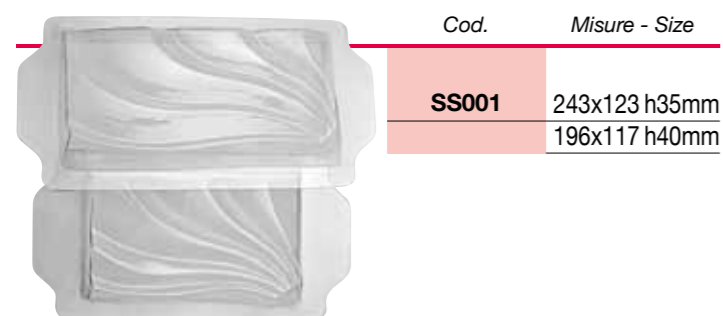

Cod.	Misure - Size
<b>SS001</b>	243x123 h35mm 196x117 h40mm

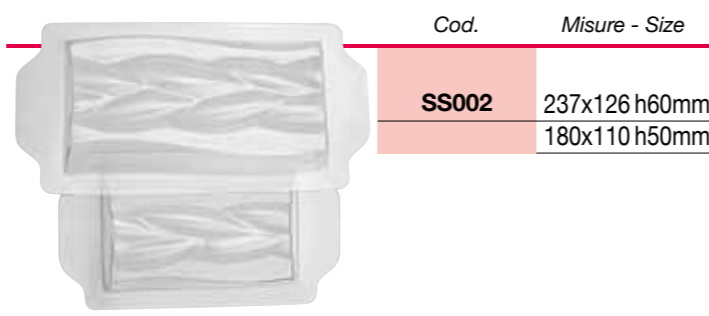

Cod.	Misure - Size
<b>SS002</b>	237x126 h60mm 180x110 h50mm

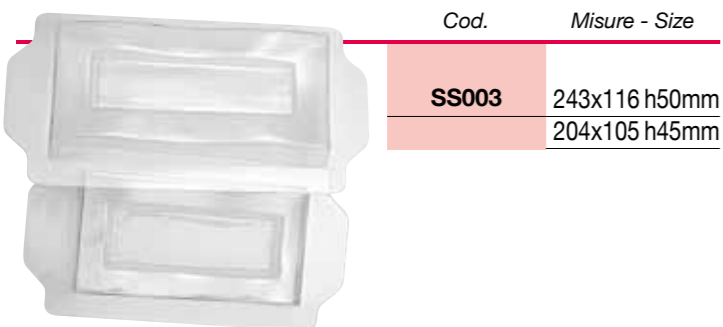

Cod.	Misure - Size
<b>SS003</b>	243x116 h50mm 204x105 h45mm

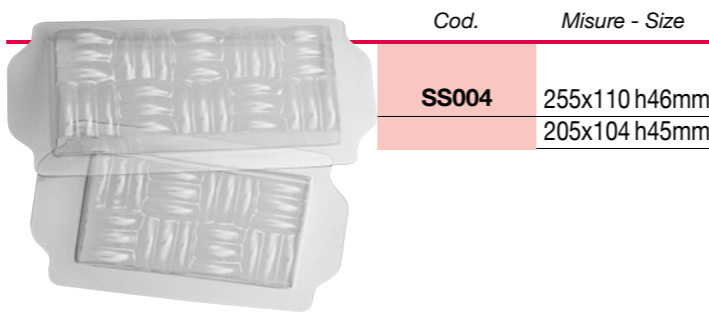

Cod.	Misure - Size
<b>SS004</b>	255x110 h46mm 205x104 h45mm

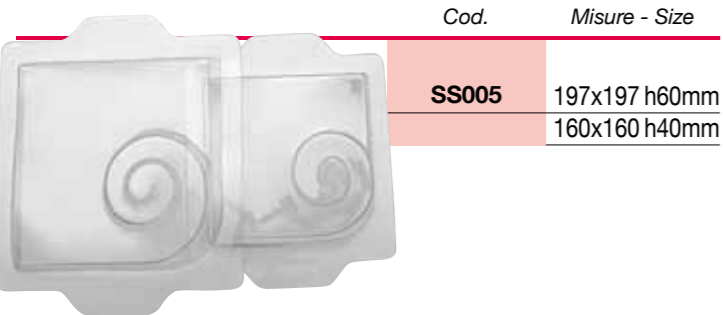

Cod.	Misure - Size
<b>SS005</b>	197x197 h60mm 160x160 h40mm

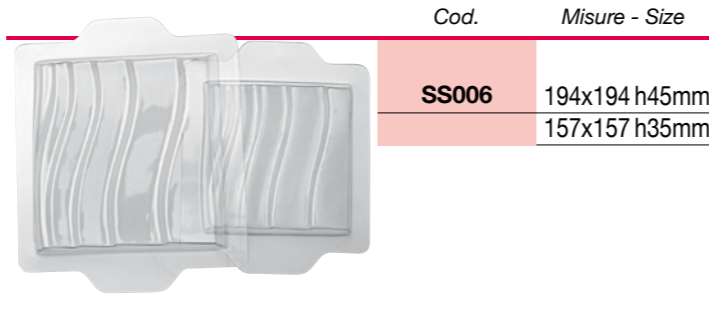

Cod.	Misure - Size
<b>SS006</b>	194x194 h45mm 157x157 h35mm

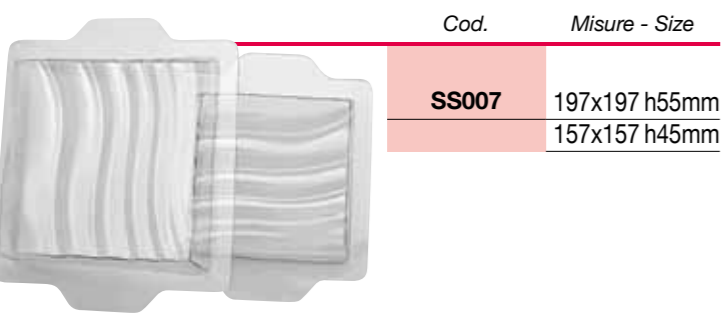

Cod.	Misure - Size
<b>SS007</b>	197x197 h55mm 157x157 h45mm

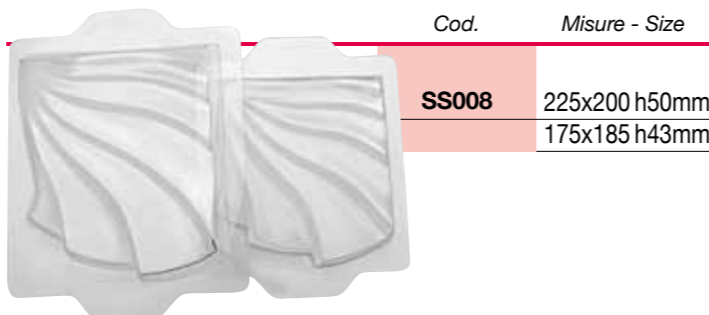

Cod.	Misure - Size
<b>SS008</b>	225x200 h50mm 175x185 h43mm

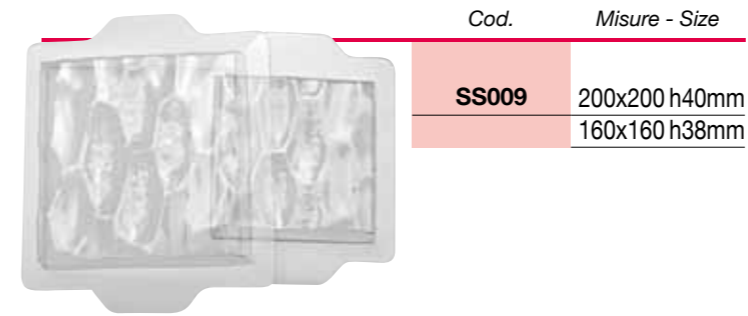

Cod.	Misure - Size
<b>SS009</b>	200x200 h40mm 160x160 h38mm

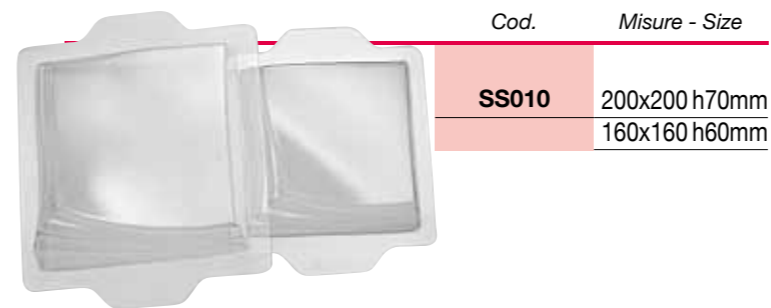

Cod.	Misure - Size
<b>SS010</b>	200x200 h70mm 160x160 h60mm

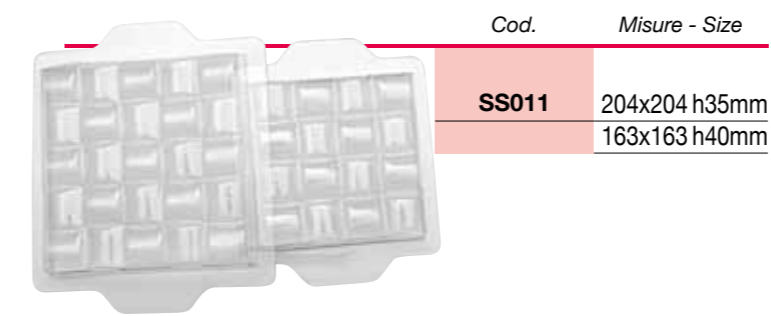

Cod.	Misure - Size
<b>SS011</b>	204x204 h35mm 163x163 h40mm

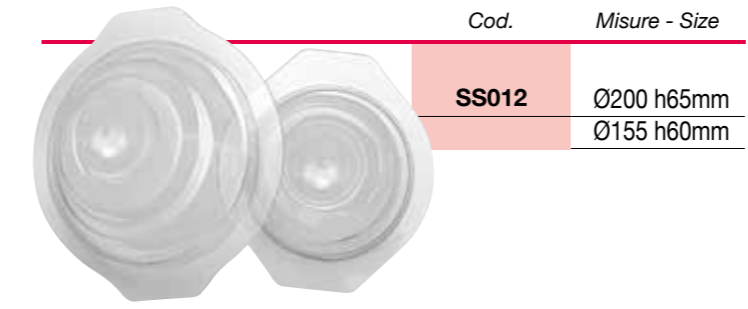

Cod.	Misure - Size
<b>SS012</b>	Ø200 h65mm Ø155 h60mm

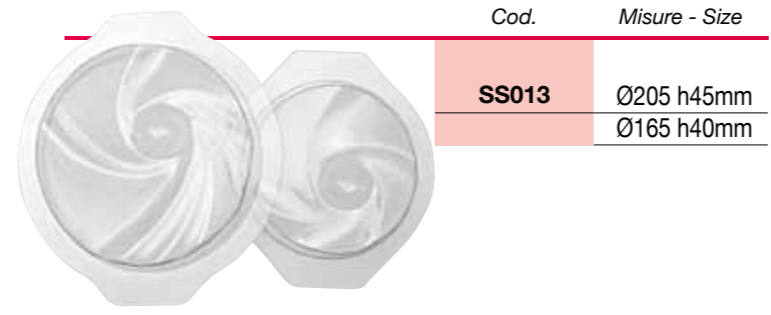

Cod.	Misure - Size
<b>SS013</b>	Ø205 h45mm Ø165 h40mm

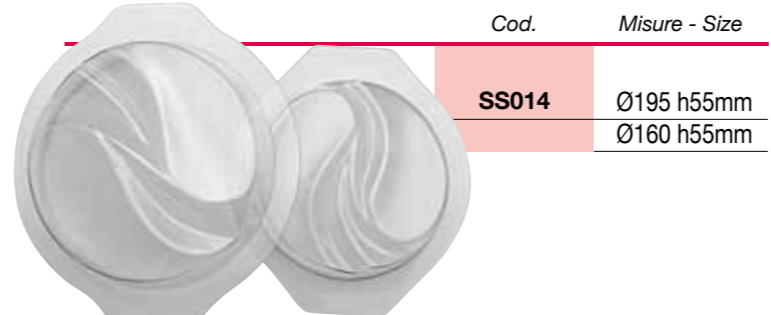

Cod.	Misure - Size
<b>SS014</b>	Ø195 h55mm Ø160 h55mm



**CONSIGLI PER L'ESTRAZIONE:**  
Lasciare per qualche minuto il semifreddo a temperatura ambiente.  
Per facilitare la sformatura immergere lo stampo in acqua non calda o passare un panno facendo attenzione a non riscaldare troppo il semifreddo.  
Dopo l'estrazione decorare con la linea coloranti spray Velvet o Chablouage

**SUGGESTIONS FOR DEMOULDING:**  
Leave the semifreddo at room temperature for a few minutes.  
For an easy demoulding, put the mould in a basin with water or use a soft cloth, paying attention not to warm the semifreddo too much.  
Decorate the semifreddo with the Velvet or Chablouage spray colours.

**STAMPI SEMIFREDDO E COTTURA - MOULDS FOR SEMIFREDDO AND BAKING**

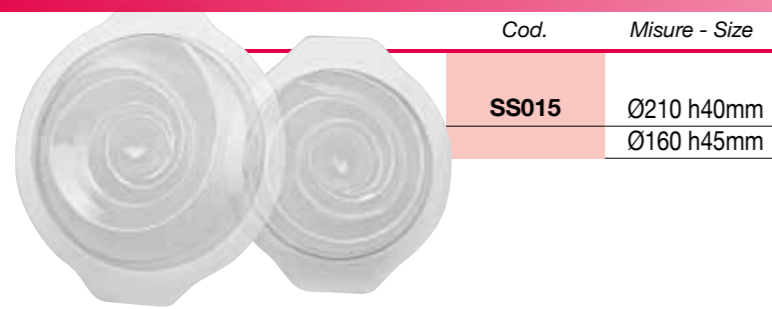

Cod.	Misure - Size
<b>SS015</b>	Ø210 h40mm Ø160 h45mm

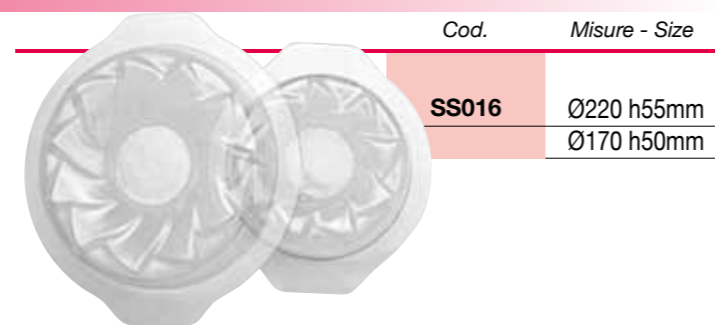

Cod.	Misure - Size
<b>SS016</b>	Ø220 h55mm Ø170 h50mm

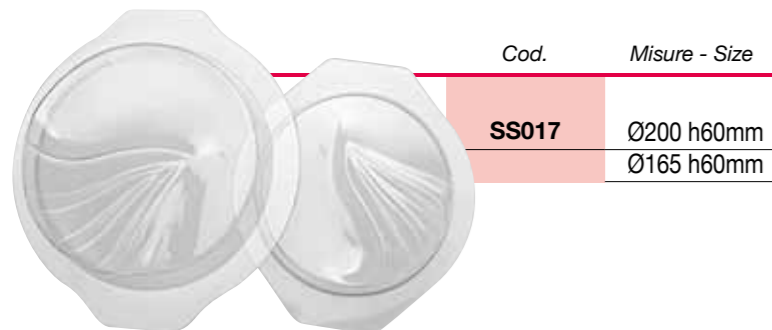

Cod.	Misure - Size
<b>SS017</b>	Ø200 h60mm Ø165 h60mm



Cod.	Misure - Size
<b>SS018</b>	Ø205 h55mm Ø160 h50mm

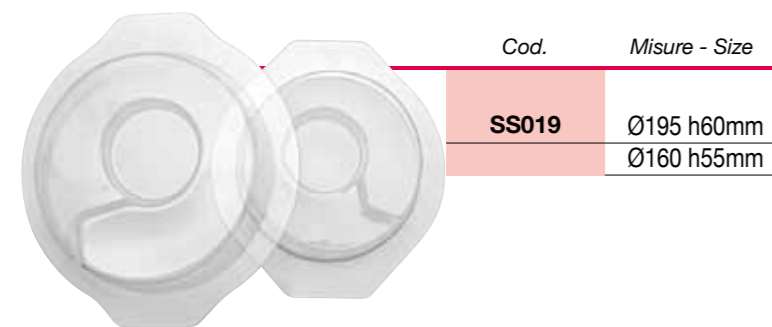

Cod.	Misure - Size
<b>SS019</b>	Ø195 h60mm Ø160 h55mm

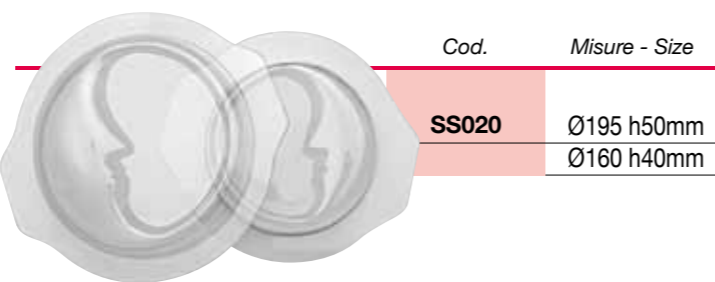

Cod.	Misure - Size
<b>SS020</b>	Ø195 h50mm Ø160 h40mm

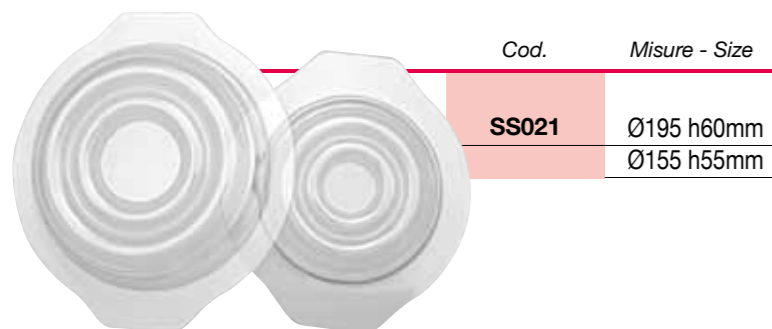

Cod.	Misure - Size
<b>SS021</b>	Ø195 h60mm Ø155 h55mm

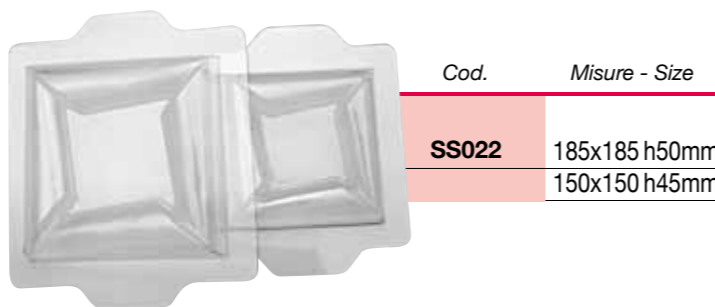

Cod.	Misure - Size
<b>SS022</b>	185x185 h50mm 150x150 h45mm

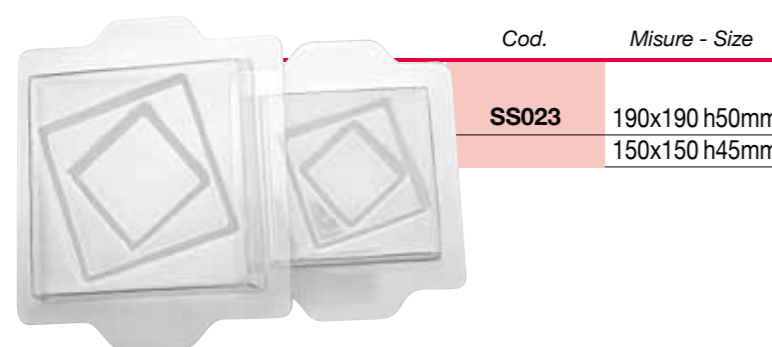

Cod.	Misure - Size
<b>SS023</b>	190x190 h50mm 150x150 h45mm

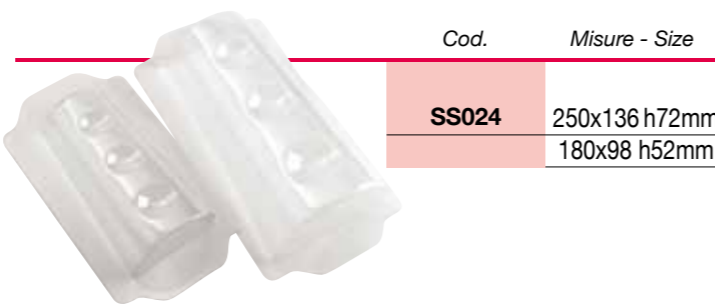

Cod.	Misure - Size
<b>SS024</b>	250x136 h72mm 180x98 h52mm

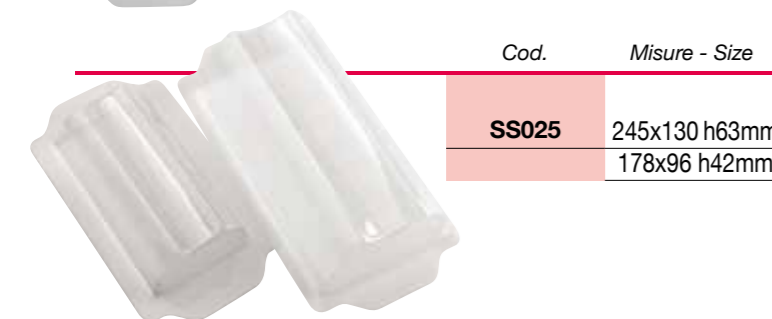

Cod.	Misure - Size
<b>SS025</b>	245x130 h63mm 178x96 h42mm



Cod.	Misure - Size
<b>SS026</b>	262x105 h69mm 190x76 h52mm

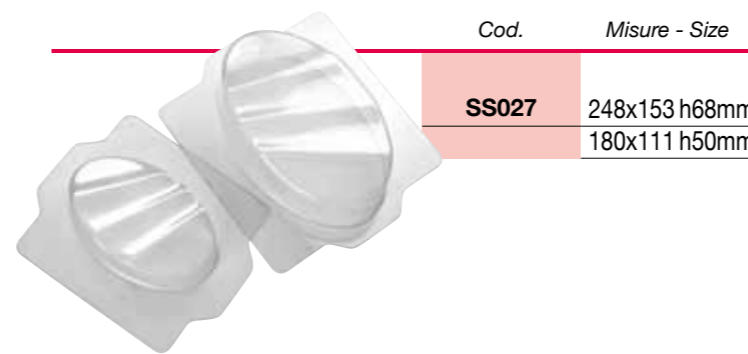

Cod.	Misure - Size
<b>SS027</b>	248x153 h68mm 180x111 h50mm

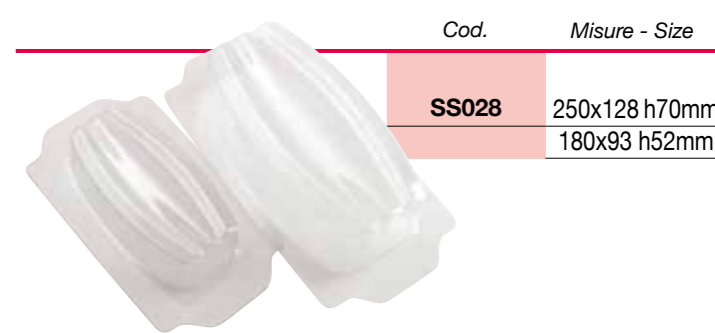

Cod.	Misure - Size
<b>SS028</b>	250x128 h70mm 180x93 h52mm

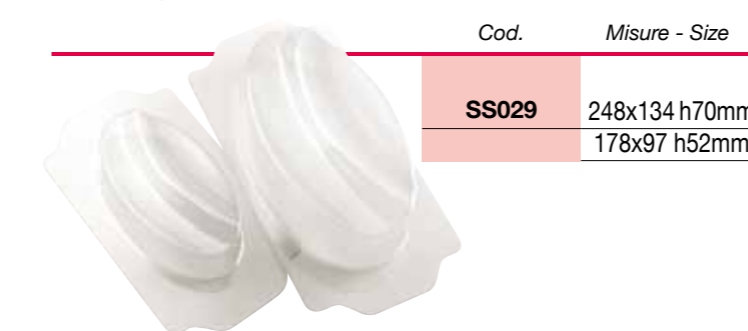

Cod.	Misure - Size
<b>SS029</b>	248x134 h70mm 178x97 h52mm



Cod.	Misure - Size
<b>SS030</b>	236x126 h70mm 172x92 h50mm



Cod.	Misure - Size
<b>SS031</b>	248x146 h68mm 178x105 h50mm



Cod.	Misure - Size
<b>SS032</b>	225x182 h74mm 177x144 h55mm

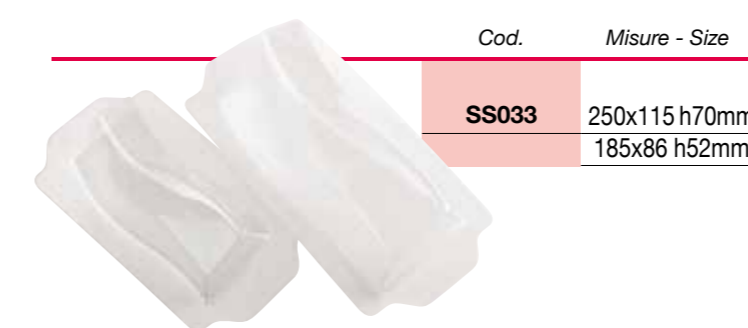

Cod.	Misure - Size
<b>SS033</b>	250x115 h70mm 185x86 h52mm

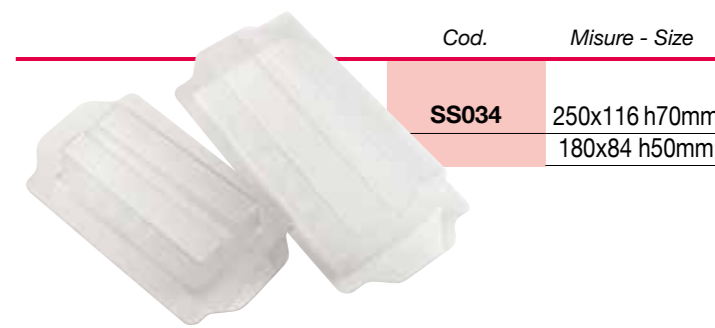

Cod.	Misure - Size
<b>SS034</b>	250x116 h70mm 180x84 h50mm

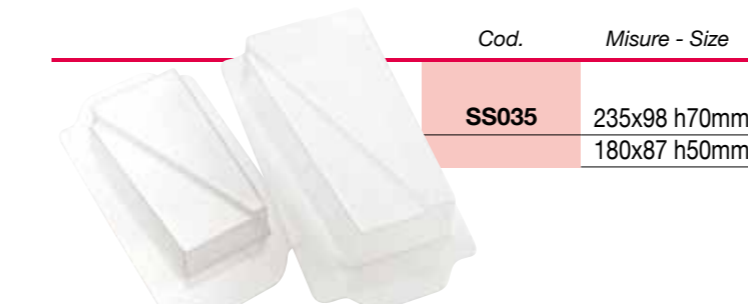

Cod.	Misure - Size
<b>SS035</b>	235x98 h70mm 180x87 h50mm

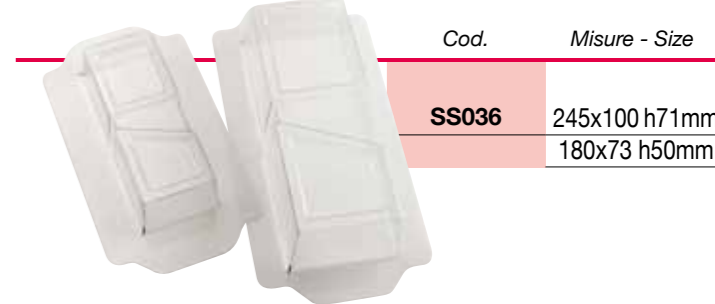

Cod.	Misure - Size
<b>SS036</b>	245x100 h71mm 180x73 h50mm



Cod.	Misure - Size
<b>SS037</b>	250x95 h62mm 180x68 h52mm



Cod.	Misure - Size
<b>SS038</b>	250x98 h70mm 180x70 h50mm

STAMPI IN PLASTICA  
PER MONOPORZIONE  
SEMIFREDDO  
REUSABLE  
MONOPORTIONS  
SEMIFREDDO MOULDS



Grammatura indicativa 130-150gr  
Blister conf. 3 pezzi. Produttività 12 semifreddi

Approximately 130-150 gr  
Blister pack 3 pcs. Productivity 12 semifreddo

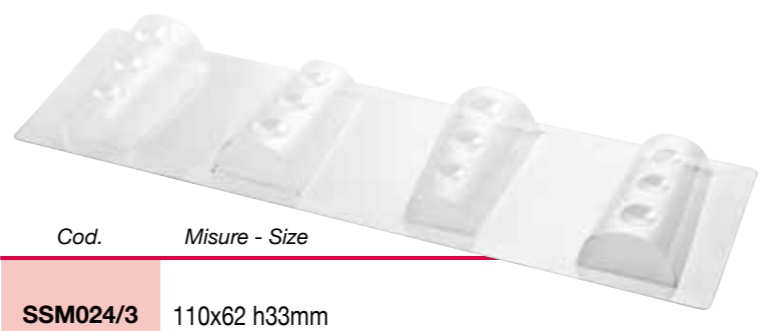

Cod. *Misure - Size*  
**SSM024/3** 110x62 h33mm



Cod. *Misure - Size*  
**SSM029/3** 110x60 h33mm

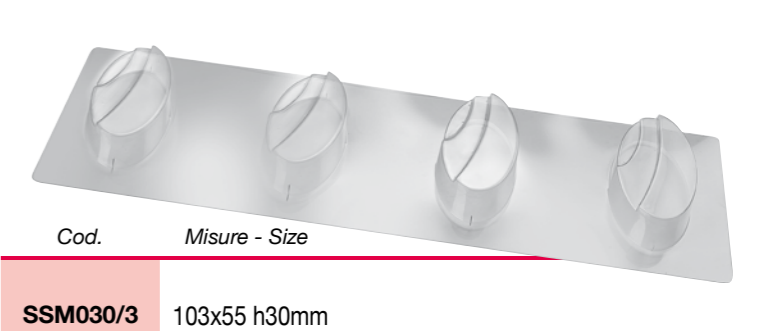

Cod. *Misure - Size*  
**SSM030/3** 103x55 h30mm

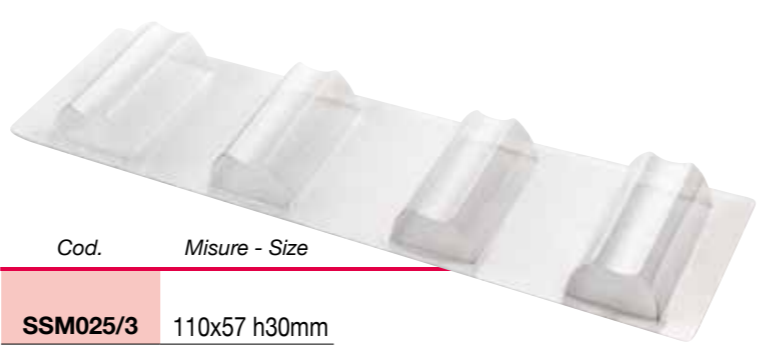

Cod. *Misure - Size*  
**SSM025/3** 110x57 h30mm

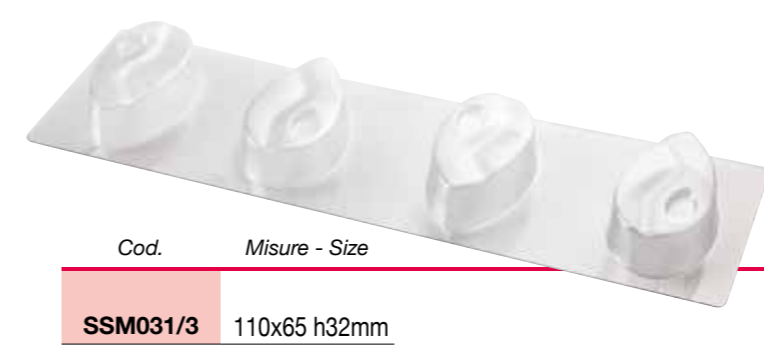

Cod. *Misure - Size*  
**SSM031/3** 110x65 h32mm



Cod. *Misure - Size*  
**SSM032/3** 118x95 h35mm

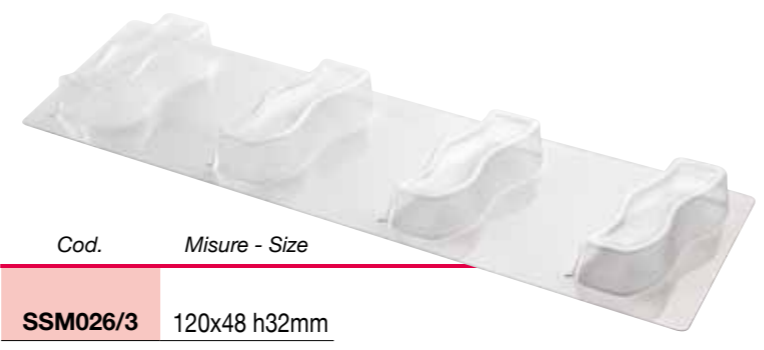

Cod. *Misure - Size*  
**SSM026/3** 120x48 h32mm

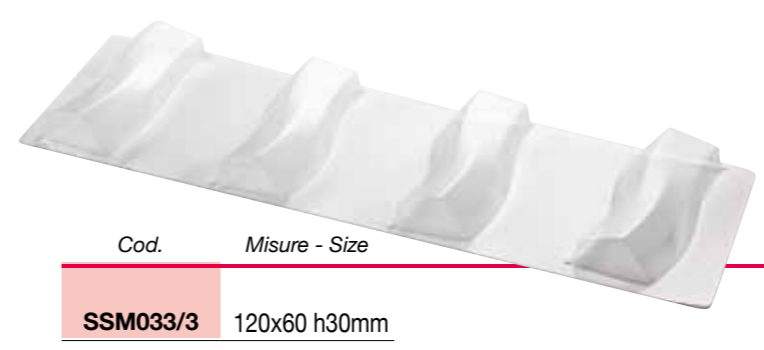

Cod. *Misure - Size*  
**SSM033/3** 120x60 h30mm

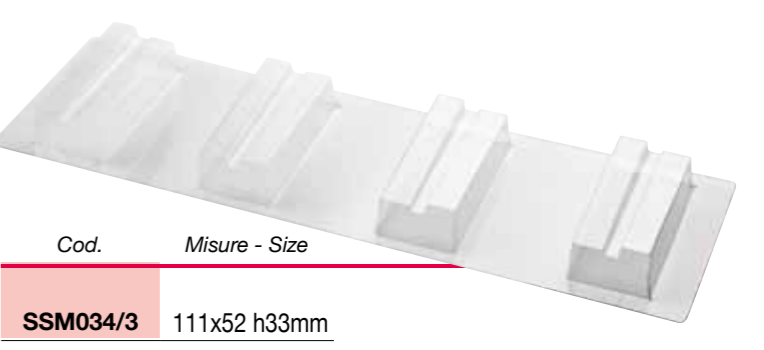

Cod. *Misure - Size*  
**SSM034/3** 111x52 h33mm

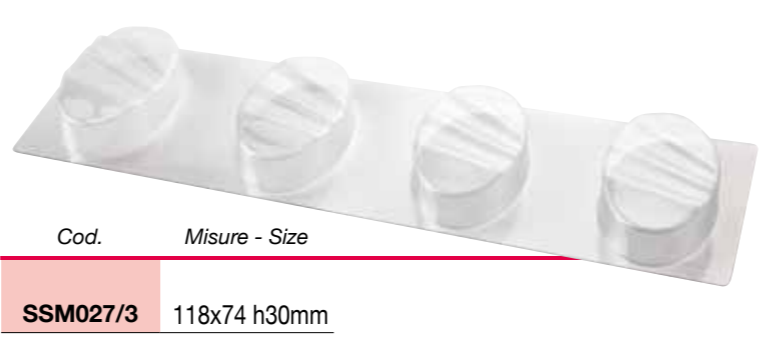

Cod. *Misure - Size*  
**SSM027/3** 118x74 h30mm

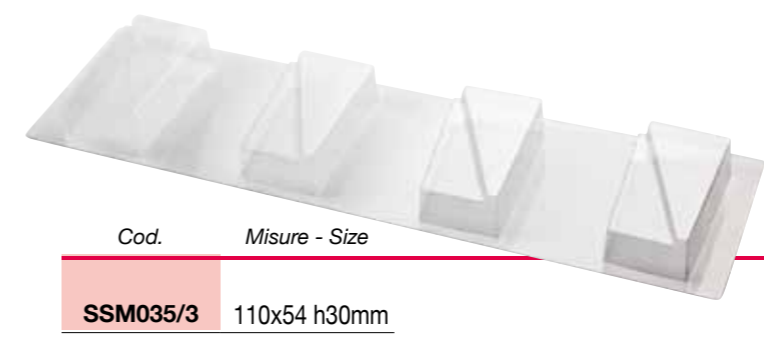

Cod. *Misure - Size*  
**SSM035/3** 110x54 h30mm

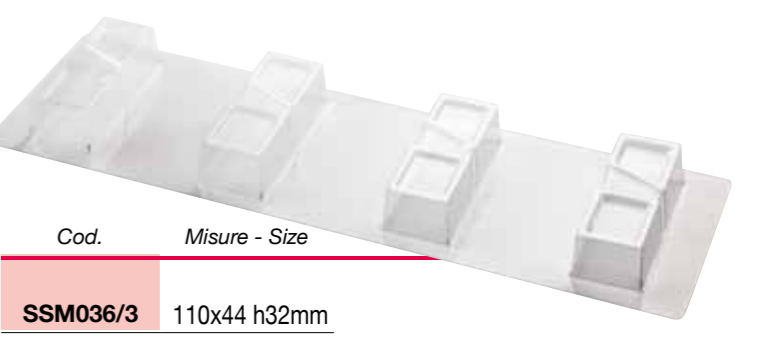

Cod. *Misure - Size*  
**SSM036/3** 110x44 h32mm

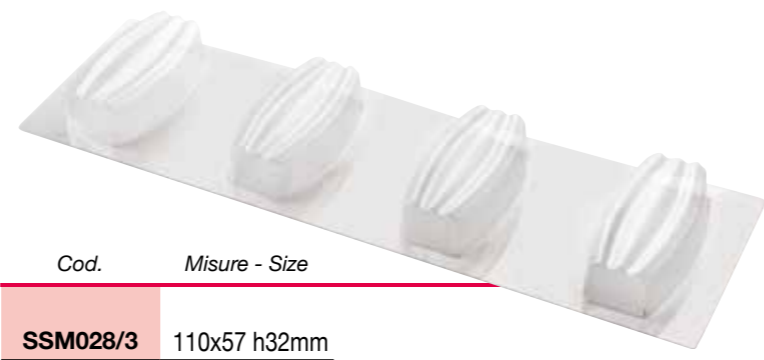

Cod. *Misure - Size*  
**SSM028/3** 110x57 h32mm

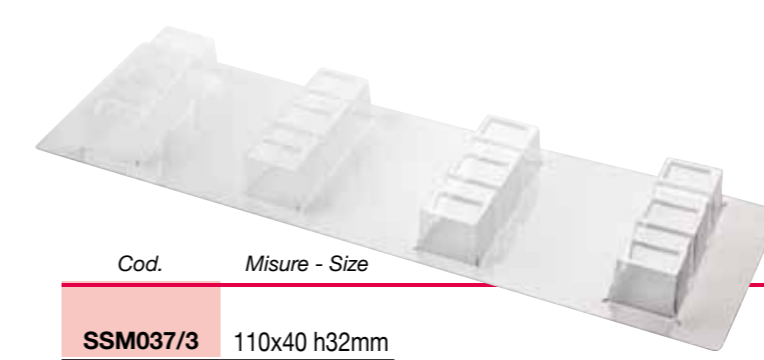

Cod. *Misure - Size*  
**SSM037/3** 110x40 h32mm

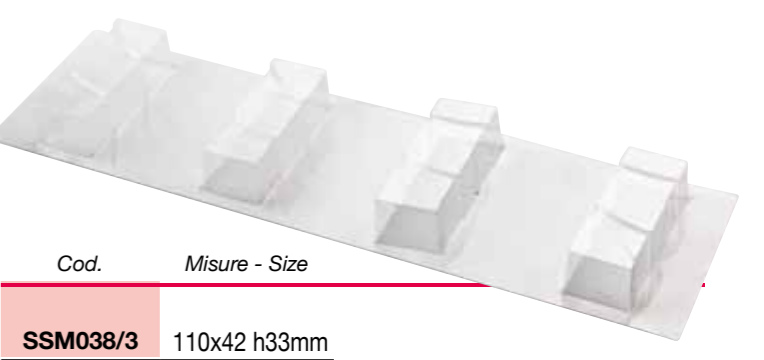

Cod. *Misure - Size*  
**SSM038/3** 110x42 h33mm

# STAMPI MONOPORZIONE IN PLASTICA MONOPORTION PLASTIC MOULDS

Stampi monoporzione in plastica, disponibili con relativi estrattori e tagliapasta.  
Possibilità di fornitura Barra singola o teglia:  
MONOP. A = 17x40 cm  
MONOP. B = 26x40 cm  
MONOP. C = 60x40 cm

Monoportion moulds made of plastic, available with their extractors and cutters.  
We also supply the moulds only or with tray:  
MONOP. A = 17x40 cm  
MONOP. B = 26x40 cm  
MONOP. C = 60x40 cm



### Estrattore/Extractor

DEVONO ESSERE ORDINATI SEPARATAMENTE  
MUST BE ORDERED SEPARATELY

### Tagliapasta/Cutter

DEVONO ESSERE ORDINATI SEPARATAMENTE  
MUST BE ORDERED SEPARATELY

### Barra/Mould

Disponibili anche solo i vassoi  
Plastic trays only available

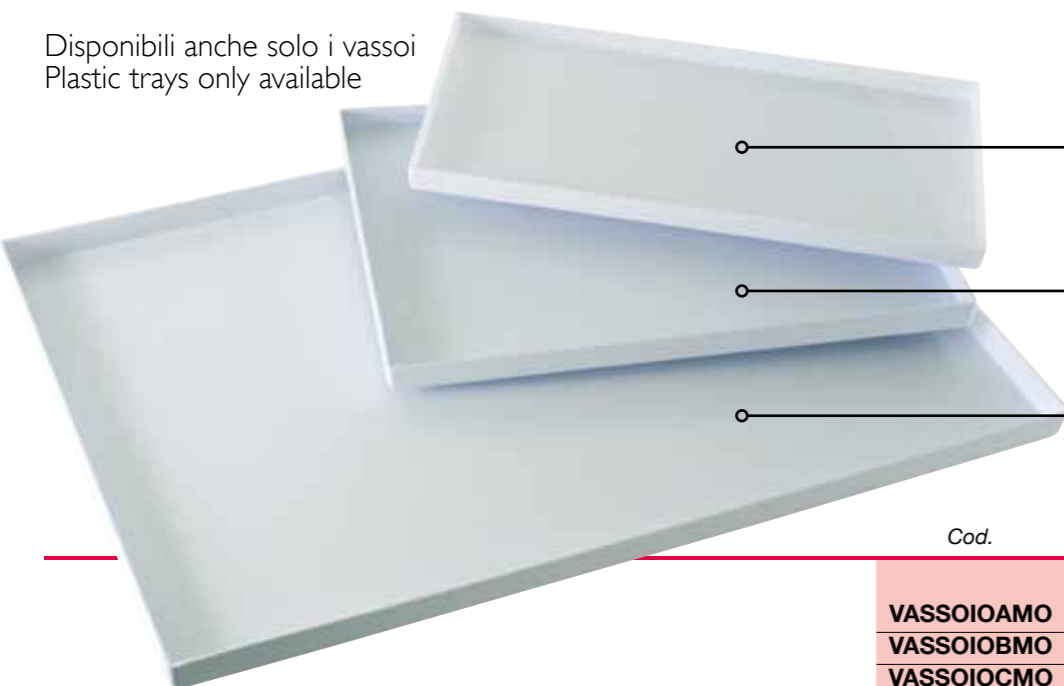

### Vassoio per MONOP. A

TRAY FOR MONOP. A

### Vassoio per MONOP. B

TRAY FOR MONOP. B

### Vassoio per MONOP. C

TRAY FOR MONOP. C

Cod.	for Monop.	Misure - Size	Cap.
VASSOIOAMO	MONOP. A	17x40 h2 cm	2 moulds
VASSOIOBMO	MONOP. B	26x40 h2 cm	3 moulds
VASSOIOCMO	MONOP. C	60x40 h2 cm	7 moulds



Forma - Shape

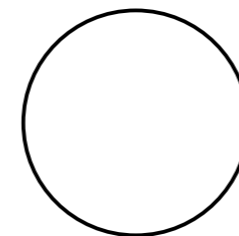

Cod.

Misure - Size

Volume

Teglia - Tray

Barre-Bars

Prod.

Extractor

Cutter

MONOP. A001	Ø65 - h40mm	75 gr	17x40cm	2	10 pcs	EM 1	TPG 1
MONOP. A01	Ø65 - h30mm	55 gr	17x40cm	2	10 pcs	EM 1	TPG 1
MONOP. A1	Ø60 - h45mm	75 gr	17x40cm	2	10 pcs	EM 01	TPG 01
MONOP. B001	Ø65 - h40mm	75 gr	26x40cm	3	15 pcs	EM 1	TPG 1
MONOP. B01	Ø65 - h30mm	55 gr	26x40cm	3	15 pcs	EM 1	TPG 1
MONOP. B1	Ø60 - h45mm	75 gr	26x40cm	3	15 pcs	EM 01	TPG 01
MONOP. C001	Ø65 - h40mm	75 gr	60x40cm	7	35 pcs	EM 1	TPG 1
MONOP. C01	Ø65 - h30mm	55 gr	60x40cm	7	35 pcs	EM 1	TPG 1
MONOP. C1	Ø60 - h45mm	75 gr	60x40cm	7	35 pcs	EM 01	TPG 01

Forma - Shape

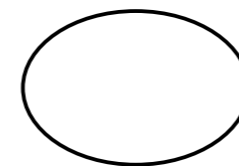

Cod.

Misure - Size

Volume

Teglia - Tray

Barre-Bars

Prod.

Extractor

Cutter

MONOP. A002	Ø65 - h40mm	75 gr	17x40cm	2	10 pcs	EM 2	TPG 2
MONOP. A02	Ø65 - h30mm	55 gr	17x40cm	2	10 pcs	EM 2	TPG 2
MONOP. A2	Ø60 - h45mm	75 gr	17x40cm	2	10 pcs	EM 02	TPG 02
MONOP. B002	Ø65 - h40mm	75 gr	26x40cm	3	15 pcs	EM 2	TPG 2
MONOP. B02	Ø65 - h30mm	55 gr	26x40cm	3	15 pcs	EM 2	TPG 2
MONOP. B2	Ø60 - h45mm	75 gr	26x40cm	3	15 pcs	EM 02	TPG 02
MONOP. C002	Ø65 - h40mm	75 gr	60x40cm	7	35 pcs	EM 2	TPG 2
MONOP. C02	Ø65 - h30mm	55 gr	60x40cm	7	35 pcs	EM 2	TPG 2
MONOP. C2	Ø60 - h45mm	75 gr	60x40cm	7	35 pcs	EM 02	TPG 02

Forma - Shape

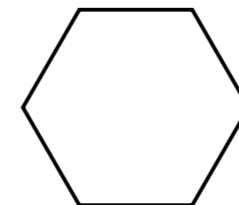

Cod.

Misure - Size

Volume

Teglia - Tray

Barre-Bars

Prod.

Extractor

Cutter

MONOP. A003	Ø65 - h40mm	75 gr	17x40cm	2	10 pcs	EM 3	TPG 3
MONOP. A03	Ø65 - h30mm	55 gr	17x40cm	2	10 pcs	EM 3	TPG 3
MONOP. A3	Ø60 - h45mm	75 gr	17x40cm	2	10 pcs	EM 03	TPG 03
MONOP. B003	Ø65 - h40mm	75 gr	26x40cm	3	15 pcs	EM 3	TPG 3
MONOP. B03	Ø65 - h30mm	55 gr	26x40cm	3	15 pcs	EM 3	TPG 3
MONOP. B3	Ø60 - h45mm	75 gr	26x40cm	3	15 pcs	EM 03	TPG 03
MONOP. C003	Ø65 - h40mm	75 gr	60x40cm	7	35 pcs	EM 3	TPG 3
MONOP. C03	Ø65 - h30mm	55 gr	60x40cm	7	35 pcs	EM 3	TPG 3
MONOP. C3	Ø60 - h45mm	75 gr	60x40cm	7	35 pcs	EM 03	TPG 03

# STAMPI SEMIFREDDO - MOULDS FOR SEMIFREDDO

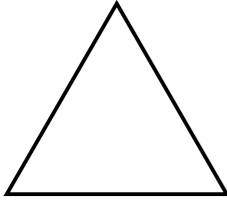
Forma - Shape	Cod.	Misure - Size	Volume	Teglia - Tray	Barre-Bars	Prod.	Extractor	Cutter
	<b>MONOP. A004</b>	Ø65 - h40mm	75 gr	17x40cm	2	10 pcs	<b>EM 4</b>	<b>TPG 4</b>
	<b>MONOP. A04</b>	Ø65 - h30mm	55 gr	17x40cm	2	10 pcs	<b>EM 4</b>	<b>TPG 4</b>
	<b>MONOP. B004</b>	Ø65 - h40mm	75 gr	26x40cm	3	15 pcs	<b>EM 4</b>	<b>TPG 4</b>
	<b>MONOP. B04</b>	Ø65 - h30mm	55 gr	26x40cm	3	15 pcs	<b>EM 4</b>	<b>TPG 4</b>
	<b>MONOP. C004</b>	Ø65 - h40mm	75 gr	60x40cm	7	35 pcs	<b>EM 4</b>	<b>TPG 4</b>
	<b>MONOP. C04</b>	Ø65 - h30mm	55 gr	60x40cm	7	35 pcs	<b>EM 4</b>	<b>TPG 4</b>

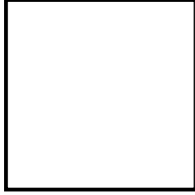
Forma - Shape	Cod.	Misure - Size	Volume	Teglia - Tray	Barre-Bars	Prod.	Extractor	Cutter
	<b>MONOP. A005</b>	Ø65 - h40mm	75 gr	17x40cm	2	10 pcs	<b>EM 5</b>	<b>TPG 5</b>
	<b>MONOP. A05</b>	Ø65 - h30mm	55 gr	17x40cm	2	10 pcs	<b>EM 5</b>	<b>TPG 5</b>
	<b>MONOP. B005</b>	Ø65 - h40mm	75 gr	26x40cm	3	15 pcs	<b>EM 5</b>	<b>TPG 5</b>
	<b>MONOP. B05</b>	Ø65 - h30mm	55 gr	26x40cm	3	15 pcs	<b>EM 5</b>	<b>TPG 5</b>
	<b>MONOP. C005</b>	Ø65 - h40mm	75 gr	60x40cm	7	35 pcs	<b>EM 5</b>	<b>TPG 5</b>
	<b>MONOP. C05</b>	Ø65 - h30mm	55 gr	60x40cm	7	35 pcs	<b>EM 5</b>	<b>TPG 5</b>

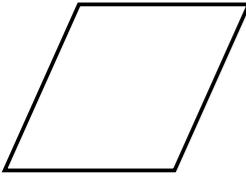
Forma - Shape	Cod.	Misure - Size	Volume	Teglia - Tray	Barre-Bars	Prod.	Extractor	Cutter
	<b>MONOP. A006</b>	Ø65 - h40mm	75 gr	17x40cm	2	10 pcs	<b>EM 6</b>	<b>TPG 6</b>
	<b>MONOP. A06</b>	Ø65 - h30mm	55 gr	17x40cm	2	10 pcs	<b>EM 6</b>	<b>TPG 6</b>
	<b>MONOP. B006</b>	Ø65 - h40mm	75 gr	26x40cm	3	15 pcs	<b>EM 6</b>	<b>TPG 6</b>
	<b>MONOP. B06</b>	Ø65 - h30mm	55 gr	26x40cm	3	15 pcs	<b>EM 6</b>	<b>TPG 6</b>
	<b>MONOP. C006</b>	Ø65 - h40mm	75 gr	60x40cm	7	35 pcs	<b>EM 6</b>	<b>TPG 6</b>
	<b>MONOP. C06</b>	Ø65 - h30mm	55 gr	60x40cm	7	35 pcs	<b>EM 6</b>	<b>TPG 6</b>

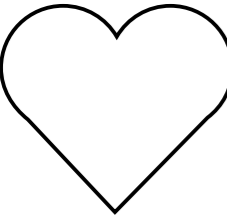
Forma - Shape	Cod.	Misure - Size	Volume	Teglia - Tray	Barre-Bars	Prod.	Extractor	Cutter
	<b>MONOP. A007</b>	Ø65 - h40mm	75 gr	17x40cm	2	10 pcs	<b>EM 7</b>	<b>TPG 7</b>
	<b>MONOP. A07</b>	Ø65 - h30mm	55 gr	17x40cm	2	10 pcs	<b>EM 7</b>	<b>TPG 7</b>
	<b>MONOP. B007</b>	Ø65 - h40mm	75 gr	26x40cm	3	15 pcs	<b>EM 7</b>	<b>TPG 7</b>
	<b>MONOP. B07</b>	Ø65 - h30mm	55 gr	26x40cm	3	15 pcs	<b>EM 7</b>	<b>TPG 7</b>
	<b>MONOP. C007</b>	Ø65 - h40mm	75 gr	60x40cm	7	35 pcs	<b>EM 7</b>	<b>TPG 7</b>
	<b>MONOP. C07</b>	Ø65 - h30mm	55 gr	60x40cm	7	35 pcs	<b>EM 7</b>	<b>TPG 7</b>

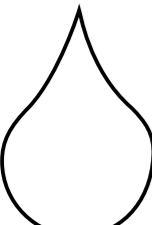
Forma - Shape	Cod.	Misure - Size	Volume	Teglia - Tray	Barre-Bars	Prod.	Extractor	Cutter
	<b>MONOP. A008</b>	Ø65 - h40mm	75 gr	17x40cm	2	10 pcs	<b>EM 8</b>	<b>TPG 8</b>
	<b>MONOP. A08</b>	Ø65 - h30mm	55 gr	17x40cm	2	10 pcs	<b>EM 8</b>	<b>TPG 8</b>
	<b>MONOP. B008</b>	Ø65 - h40mm	75 gr	26x40cm	3	15 pcs	<b>EM 8</b>	<b>TPG 8</b>
	<b>MONOP. B08</b>	Ø65 - h30mm	55 gr	26x40cm	3	15 pcs	<b>EM 8</b>	<b>TPG 8</b>
	<b>MONOP. C008</b>	Ø65 - h40mm	75 gr	60x40cm	7	35 pcs	<b>EM 8</b>	<b>TPG 8</b>
	<b>MONOP. C08</b>	Ø65 - h30mm	55 gr	60x40cm	7	35 pcs	<b>EM 8</b>	<b>TPG 8</b>

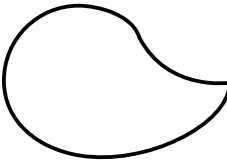
Forma - Shape	Cod.	Misure - Size	Volume	Teglia - Tray	Barre-Bars	Prod.	Extractor	Cutter
	<b>MONOP. A009</b>	Ø65 - h40mm	75 gr	17x40cm	2	10 pcs	<b>EM 9</b>	<b>TPG 9</b>
	<b>MONOP. A09</b>	Ø65 - h30mm	55 gr	17x40cm	2	10 pcs	<b>EM 9</b>	<b>TPG 9</b>
	<b>MONOP. B009</b>	Ø65 - h40mm	75 gr	26x40cm	3	15 pcs	<b>EM 9</b>	<b>TPG 9</b>
	<b>MONOP. B09</b>	Ø65 - h30mm	55 gr	26x40cm	3	15 pcs	<b>EM 9</b>	<b>TPG 9</b>
	<b>MONOP. C009</b>	Ø65 - h40mm	75 gr	60x40cm	7	35 pcs	<b>EM 9</b>	<b>TPG 9</b>
	<b>MONOP. C09</b>	Ø65 - h30mm	55 gr	60x40cm	7	35 pcs	<b>EM 9</b>	<b>TPG 9</b>

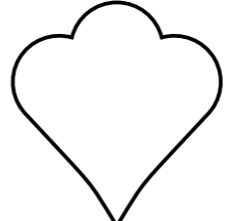
Forma - Shape	Cod.	Misure - Size	Volume	Teglia - Tray	Barre-Bars	Prod.	Extractor	Cutter
	<b>MONOP. A0010</b>	Ø65 - h40mm	75 gr	17x40cm	2	10 pcs	<b>EM 10</b>	<b>TPG 10</b>
	<b>MONOP. A010</b>	Ø65 - h30mm	55 gr	17x40cm	2	10 pcs	<b>EM 10</b>	<b>TPG 10</b>
	<b>MONOP. B0010</b>	Ø65 - h40mm	75 gr	26x40cm	3	15 pcs	<b>EM 10</b>	<b>TPG 10</b>
	<b>MONOP. B010</b>	Ø65 - h30mm	55 gr	26x40cm	3	15 pcs	<b>EM 10</b>	<b>TPG 10</b>
	<b>MONOP. C0010</b>	Ø65 - h40mm	75 gr	60x40cm	7	35 pcs	<b>EM 10</b>	<b>TPG 10</b>
	<b>MONOP. C010</b>	Ø65 - h30mm	55 gr	60x40cm	7	35 pcs	<b>EM 10</b>	<b>TPG 10</b>

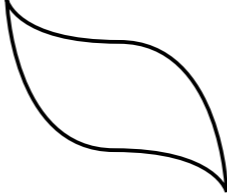
Forma - Shape	Cod.	Misure - Size	Volume	Teglia - Tray	Barre-Bars	Prod.	Extractor	Cutter
	<b>MONOP. A0011</b>	Ø65 - h40mm	75 gr	17x40cm	2	10 pcs	<b>EM 11</b>	<b>TPG 11</b>
	<b>MONOP. A011</b>	Ø65 - h30mm	55 gr	17x40cm	2	10 pcs	<b>EM 11</b>	<b>TPG 11</b>
	<b>MONOP. B0011</b>	Ø65 - h40mm	75 gr	26x40cm	3	15 pcs	<b>EM 11</b>	<b>TPG 11</b>
	<b>MONOP. B011</b>	Ø65 - h30mm	55 gr	26x40cm	3	15 pcs	<b>EM 11</b>	<b>TPG 11</b>
	<b>MONOP. C0011</b>	Ø65 - h40mm	75 gr	60x40cm	7	35 pcs	<b>EM 11</b>	<b>TPG 11</b>
	<b>MONOP. C011</b>	Ø65 - h30mm	55 gr	60x40cm	7	35 pcs	<b>EM 11</b>	<b>TPG 11</b>

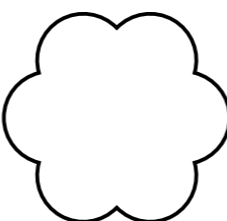
Forma - Shape	Cod.	Misure - Size	Volume	Teglia - Tray	Barre-Bars	Prod.	Extractor	Cutter
	<b>MONOP. A0012</b>	Ø65 - h40mm	75 gr	17x40cm	2	10 pcs	<b>EM 12</b>	<b>TPG 12</b>
	<b>MONOP. A012</b>	Ø65 - h30mm	55 gr	17x40cm	2	10 pcs	<b>EM 12</b>	<b>TPG 12</b>
	<b>MONOP. B0012</b>	Ø65 - h40mm	75 gr	26x40cm	3	15 pcs	<b>EM 12</b>	<b>TPG 12</b>
	<b>MONOP. B012</b>	Ø65 - h30mm	55 gr	26x40cm	3	15 pcs	<b>EM 12</b>	<b>TPG 12</b>
	<b>MONOP. C0012</b>	Ø65 - h40mm	75 gr	60x40cm	7	35 pcs	<b>EM 12</b>	<b>TPG 12</b>
	<b>MONOP. C012</b>	Ø65 - h30mm	55 gr	60x40cm	7	35 pcs	<b>EM 12</b>	<b>TPG 12</b>

Forma - Shape	Cod.	Misure - Size	Volume	Teglia - Tray	Barre-Bars	Prod.	Extractor	Cutter
	<b>MONOP. A0013</b>	Ø65 - h40mm	75 gr	17x40cm	2	10 pcs	<b>EM 13</b>	<b>TPG 13</b>
	<b>MONOP. A013</b>	Ø65 - h30mm	55 gr	17x40cm	2	10 pcs	<b>EM 13</b>	<b>TPG 13</b>
	<b>MONOP. B0013</b>	Ø65 - h40mm	75 gr	26x40cm	3	15 pcs	<b>EM 13</b>	<b>TPG 13</b>
	<b>MONOP. B013</b>	Ø65 - h30mm	55 gr	26x40cm	3	15 pcs	<b>EM 13</b>	<b>TPG 13</b>
	<b>MONOP. C0013</b>	Ø65 - h40mm	75 gr	60x40cm	7	35 pcs	<b>EM 13</b>	<b>TPG 13</b>
	<b>MONOP. C013</b>	Ø65 - h30mm	55 gr	60x40cm	7	35 pcs	<b>EM 13</b>	<b>TPG 13</b>

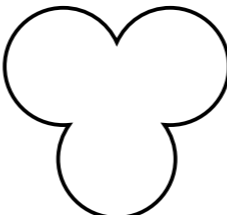
Forma - Shape	Cod.	Misure - Size	Volume	Teglia - Tray	Barre-Bars	Prod.	Extractor	Cutter
	<b>MONOP. A0014</b>	Ø65 - h40mm	75 gr	17x40cm	2	10 pcs	<b>EM 14</b>	<b>TPG 14</b>
	<b>MONOP. A014</b>	Ø65 - h30mm	55 gr	17x40cm	2	10 pcs	<b>EM 14</b>	<b>TPG 14</b>
	<b>MONOP. B0014</b>	Ø65 - h40mm	75 gr	26x40cm	3	15 pcs	<b>EM 14</b>	<b>TPG 14</b>
	<b>MONOP. B014</b>	Ø65 - h30mm	55 gr	26x40cm	3	15 pcs	<b>EM 14</b>	<b>TPG 14</b>
	<b>MONOP. C0014</b>	Ø65 - h40mm	75 gr	60x40cm	7	35 pcs	<b>EM 14</b>	<b>TPG 14</b>
	<b>MONOP. C014</b>	Ø65 - h30mm	55 gr	60x40cm	7	35 pcs	<b>EM 14</b>	<b>TPG 14</b>

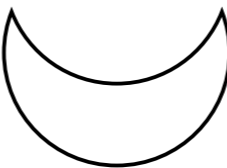
Forma - Shape	Cod.	Misure - Size	Volume	Teglia - Tray	Barre-Bars	Prod.	Extractor	Cutter
	<b>MONOP. A0015</b>	Ø65 - h40mm	75 gr	17x40cm	2	10 pcs	<b>EM 15</b>	<b>TPG 15</b>
	<b>MONOP. A015</b>	Ø65 - h30mm	55 gr	17x40cm	2	10 pcs	<b>EM 15</b>	<b>TPG 15</b>
	<b>MONOP. B0015</b>	Ø65 - h40mm	75 gr	26x40cm	3	15 pcs	<b>EM 15</b>	<b>TPG 15</b>
	<b>MONOP. B015</b>	Ø65 - h30mm	55 gr	26x40cm	3	15 pcs	<b>EM 15</b>	<b>TPG 15</b>
	<b>MONOP. C0015</b>	Ø65 - h40mm	75 gr	60x40cm	7	35 pcs	<b>EM 15</b>	<b>TPG 15</b>
	<b>MONOP. C015</b>	Ø65 - h30mm	55 gr	60x40cm	7	35 pcs	<b>EM 15</b>	<b>TPG 15</b>

# STAMPI MIGNON IN PLASTICA PETIT-FOURS PLASTIC MOULDS

Stampi mignon in plastica, disponibili con relativi estrattori e tagliapasta.  
Possibilità di fornitura barra singola o teglia:

MIGNON. A = 20x40 cm  
MIGNON. B = 30x40 cm  
MIGNON. C = 60x40 cm

Mignon moulds made of plastic, available with their extractors and cutters.  
We also supply the moulds only or with tray:

MIGNON. A = 20x40 cm  
MIGNON. B = 30x40 cm  
MIGNON. C = 60x40 cm



**Estrattore/Extractor**

DEVONO ESSERE ORDINATI SEPARATAMENTE  
MUST BE ORDERED SEPARATELY

**Tagliapasta/Cutter**

DEVONO ESSERE ORDINATI SEPARATAMENTE  
MUST BE ORDERED SEPARATELY

**Barra/Mould**

Disponibili anche solo i vassoi  
Plastic trays only available

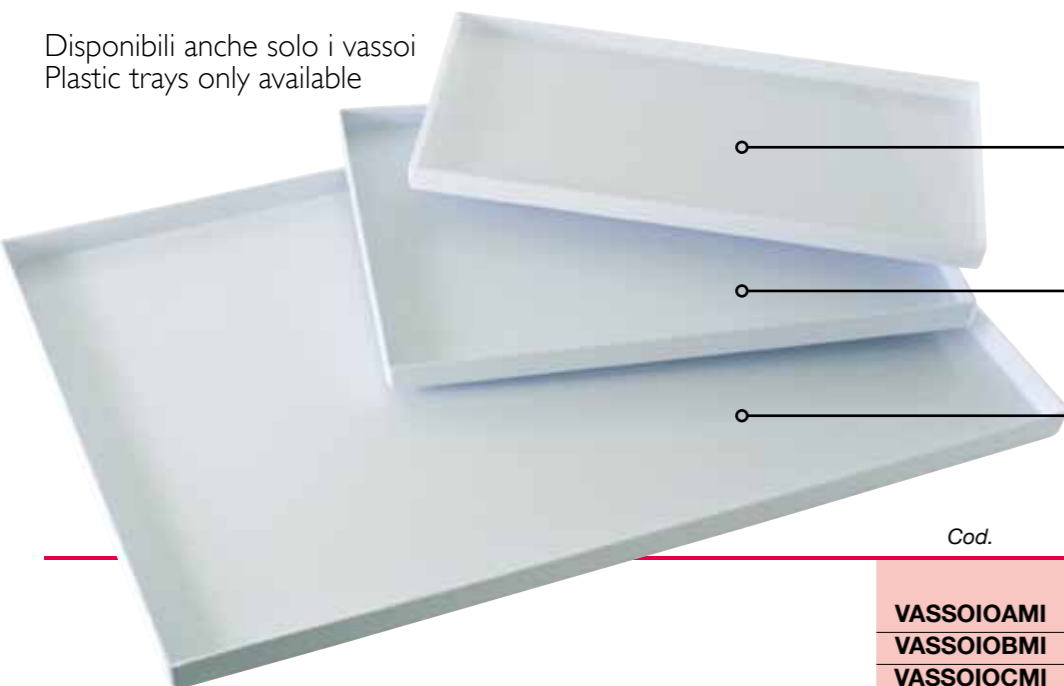

**Vassoio per MIGNON. A**

TRAY FOR MIGNON. A

**Vassoio per MIGNON. B**

TRAY FOR MIGNON. B

**Vassoio per MIGNON. C**

TRAY FOR MIGNON. C

Cod.	for Monop.	Misure - Size	Cap.
VASSOIOAMI	MIGNON. A	20x40 h1 cm	2 moulds
VASSOIOBMI	MIGNON. B	30x40 h1 cm	3 moulds
VASSOIOCFMI	MIGNON. C	59x39 h1 cm	7 moulds

Forma - Shape

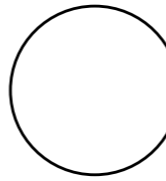

Cod.	Misure - Size	Volume	Teglia - Tray	Barre-Bars	Prod.	Extractor	Cutter
MIGNON. A001	Ø40 - h25mm	20 gr	20x40cm	2	32 pcs	ED 1	TPM 1
MIGNON. B001	Ø40 - h25mm	20 gr	30x40cm	3	48 pcs	ED 1	TPM 1
MIGNON. C001	Ø40 - h25mm	20 gr	60x40cm	6	96 pcs	ED 1	TPM 1

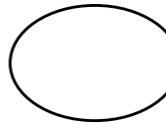

Cod.	Misure - Size	Volume	Teglia - Tray	Barre-Bars	Prod.	Extractor	Cutter
MIGNON. A002	Ø40 - h25mm	20 gr	20x40cm	2	32 pcs	ED 2	TPM 2
MIGNON. B002	Ø40 - h25mm	20 gr	30x40cm	3	48 pcs	ED 2	TPM 2
MIGNON. C002	Ø40 - h25mm	20 gr	60x40cm	6	96 pcs	ED 2	TPM 2

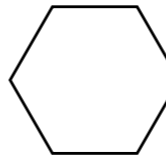

Cod.	Misure - Size	Volume	Teglia - Tray	Barre-Bars	Prod.	Extractor	Cutter
MIGNON. A003	Ø40 - h25mm	20 gr	20x40cm	2	32 pcs	ED 3	TPM 3
MIGNON. B003	Ø40 - h25mm	20 gr	30x40cm	3	48 pcs	ED 3	TPM 3
MIGNON. C003	Ø40 - h25mm	20 gr	60x40cm	6	96 pcs	ED 3	TPM 3



Cod.	Misure - Size	Volume	Teglia - Tray	Barre-Bars	Prod.	Extractor	Cutter
MIGNON. A004	Ø40 - h25mm	20 gr	20x40cm	2	32 pcs	ED 4	TPM 4
MIGNON. B004	Ø40 - h25mm	20 gr	30x40cm	3	48 pcs	ED 4	TPM 4
MIGNON. C004	Ø40 - h25mm	20 gr	60x40cm	6	96 pcs	ED 4	TPM 4



Cod.	Misure - Size	Volume	Teglia - Tray	Barre-Bars	Prod.	Extractor	Cutter
MIGNON. A005	Ø40 - h25mm	20 gr	20x40cm	2	32 pcs	ED 5	TPM 5
MIGNON. B005	Ø40 - h25mm	20 gr	30x40cm	3	48 pcs	ED 5	TPM 5
MIGNON. C005	Ø40 - h25mm	20 gr	60x40cm	6	96 pcs	ED 5	TPM 5

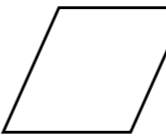

Cod.	Misure - Size	Volume	Teglia - Tray	Barre-Bars	Prod.	Extractor	Cutter
MIGNON. A006	Ø40 - h25mm	20 gr	20x40cm	2	32 pcs	ED 6	TPM 6
MIGNON. B006	Ø40 - h25mm	20 gr	30x40cm	3	48 pcs	ED 6	TPM 6
MIGNON. C006	Ø40 - h25mm	20 gr	60x40cm	6	96 pcs	ED 6	TPM 6



Cod.	Misure - Size	Volume	Teglia - Tray	Barre-Bars	Prod.	Extractor	Cutter
MIGNON. A007	Ø40 - h25mm	20 gr	20x40cm	2	32 pcs	ED 7	TPM 7
MIGNON. B007	Ø40 - h25mm	20 gr	30x40cm	3	48 pcs	ED 7	TPM 7
MIGNON. C007	Ø40 - h25mm	20 gr	60x40cm	6	96 pcs	ED 7	TPM 7

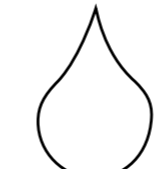

Cod.	Misure - Size	Volume	Teglia - Tray	Barre-Bars	Prod.	Extractor	Cutter
MIGNON. A008	Ø40 - h25mm	20 gr	20x40cm	2	32 pcs	ED 8	TPM 8
MIGNON. B008	Ø40 - h25mm	20 gr	30x40cm	3	48 pcs	ED 8	TPM 8
MIGNON. C008	Ø40 - h25mm	20 gr	60x40cm	6	96 pcs	ED 8	TPM 8

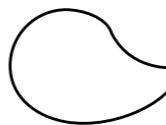

Cod.	Misure - Size	Volume	Teglia - Tray	Barre-Bars	Prod.	Extractor	Cutter
MIGNON. A009	Ø40 - h25mm	20 gr	20x40cm	2	32 pcs	ED 9	TPM 9
MIGNON. B009	Ø40 - h25mm	20 gr	30x40cm	3	48 pcs	ED 9	TPM 9
MIGNON. C009	Ø40 - h25mm	20 gr	60x40cm	6	96 pcs	ED 9	TPM 9

## STAMPI EXTRA IN PLASTICA EXTRA PLASTIC MOULDS

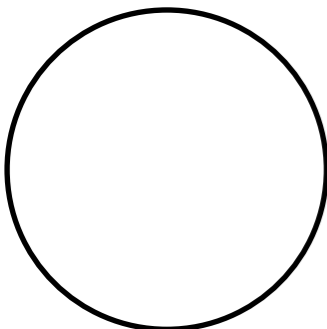

Forma - Shape	Cod.	Misure - Size	Volume	Teglia - Tray	Barre-Bars	Prod.	Extractor	Cutter
	<b>EXTRA A</b>	Ø80 - h 40 mm	100 gr	17x40cm	2	8 pcs	<b>EEX1</b>	<b>TPEX 1</b>
	<b>EXTRA A01</b>	Ø75 - h 31 mm	75 gr	17x40cm	2	8 pcs	<b>EEX01</b>	
	<b>EXTRA A001</b>	Ø85 - h 31 mm	85 gr	17x40cm	2	8 pcs	<b>EEX001</b>	
	<b>EXTRA A0001</b>	Ø90 - h 40 mm	110 gr	17x40cm	2	8 pcs	<b>EEX0001</b>	
	<b>EXTRA C</b>	Ø80 - h 40 mm	100 gr	60x40cm	7	28 pcs	<b>EEX1</b>	<b>TPEX 1</b>
	<b>EXTRA C01</b>	Ø75 - h 31 mm	75 gr	60x40cm	7	28 pcs	<b>EEX01</b>	
	<b>EXTRA C001</b>	Ø85 - h 31 mm	85 gr	60x40cm	7	28 pcs	<b>EEX001</b>	
	<b>EXTRA C0001</b>	Ø90 - h 40 mm	110 gr	60x40cm	7	24 pcs	<b>EEX0001</b>	

NB: LE TEGLIE SONO INCLUSE NELL'ARTICOLO, MENTRE GLI ESTRATTORI E I TAGLIAPASTA DEVONO ESSERE ORDINATI SEPARATAMENTE.  
NB: TRAYS ARE INCLUDED IN THE ITEM, WHILE EXTRACTORS AND CUTTERS MUST BE ORDERED SEPARATELY.

## STAMPI TORTA ROTONDA IN PLASTICA ROUND CAKE PLASTIC MOULDS



Cod.	Misure - Size	H	Teglia - Tray	Misure - Size	Extractors
<b>T6 R5</b>	2x Ø16cm - 2x Ø18cm - 2x Ø20cm	5cm	<b>TEMAXI</b>	60x40cm	<b>ER3</b> kit 3 pcs
<b>T6 R4</b>	2x Ø16cm - 2x Ø18cm - 2x Ø20cm	4cm	<b>TEMAXI</b>	60x40cm	<b>ER3</b> kit 3 pcs

NB: LE TEGLIE SONO INCLUSE NELL'ARTICOLO, MENTRE GLI ESTRATTORI E I TAGLIAPASTA DEVONO ESSERE ORDINATI SEPARATAMENTE.  
NB: TRAYS ARE INCLUDED IN THE ITEM, WHILE EXTRACTORS AND CUTTERS MUST BE ORDERED SEPARATELY.

## STAMPI PIRAMIDE IN PLASTICA PYRAMID PLASTIC MOULDS

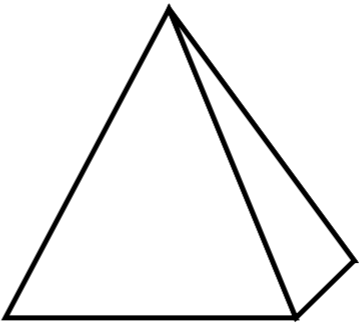

Forma - Shape	Cod.	Misure - Size	Teglia - Tray	Barre-Bars	Prod.
	<b>PIRAMTP 02</b>	70x70 - h 60 mm	17x40cm	2	10 pcs
	<b>PIRAMTP 03</b>	70x70 - h 60 mm	26x40cm	3	15 pcs
	<b>PIRAMTP 07</b>	70x70 - h 60 mm	60x40cm	7	35 pcs

## STAMPI TORTA OTTAGONALE IN PLASTICA OCTAGONAL CAKE PLASTIC MOULDS





Cod.	Misure - Size	H	Teglia - Tray	Misure - Size	Extractors
<b>T6 O5</b>	2x Ø16cm - 2x Ø18cm - 2x Ø20cm	5cm	<b>TEMAXI</b>	60x40cm	<b>EO3</b> kit 3 pcs
<b>T6 O4</b>	2x Ø16cm - 2x Ø18cm - 2x Ø20cm	4cm	<b>TEMAXI</b>	60x40cm	<b>EO3</b> kit 3 pcs

NB: LE TEGLIE SONO INCLUSE NELL'ARTICOLO, MENTRE GLI ESTRATTORI E I TAGLIAPASTA DEVONO ESSERE ORDINATI SEPARATAMENTE.  
NB: TRAYS ARE INCLUDED IN THE ITEM, WHILE EXTRACTORS AND CUTTERS MUST BE ORDERED SEPARATELY.





## STAMPI IN PLASTICA PER TRONCHI PLASTIC MOULDS FOR LOGS

Forma - Shape	Cod.	Misure - Size
	<b>ST1</b>	480x65 mm - h 65 mm

Forma - Shape	Cod.	Misure - Size
	<b>ST2</b>	480x65 mm - h 50 mm
	<b>ST4</b>	480x50 mm - h 40 mm

Forma - Shape	Cod.	Misure - Size
	<b>ST3</b>	480x65 mm - h 50 mm

Forma - Shape	Cod.	Misure - Size
	<b>STN1</b>	480x65 mm - h 65 mm

Forma - Shape	Cod.	Misure - Size
	<b>STN2</b>	480x65 mm - h 50 mm

Forma - Shape	Cod.	Misure - Size
	<b>STN3</b>	480x65 mm - h 50 mm

Stampi in plastica per tronchi con sagoma interna flessibile  
Plastic moulds for logs with internal flexible shape



Forma - Shape	Cod.	Misure - Size	Forma - Shape	Cod.	Misure - Size	Forma - Shape	Cod.	Misure - Size
Tronco - Log	<b>ST7</b>	230x90 h70mm	Tronco - Log	<b>ST8</b>	370x90 h70mm	Orsetto - Bear	<b>ST9</b>	250x100 h70mm

## STAMPI IN PLASTICA PLASTIC MOULDS

Forma - Shape	Cod.	Misure - Size	Pack
	<b>RKS 10</b>	Ø75 h50mm	10 pcs
	<b>RKS 20</b>	Ø75 h50mm	20 pcs

Forma - Shape	Cod.	Misure - Size	Pack
	<b>SKB 10</b>	Ø65 h60mm	10 pcs
	<b>SKB 20</b>	Ø65 h60mm	20 pcs

## STAMPI IN PLASTICA PER SEMISFERE PLASTIC MOULDS FOR SEMISPHERES

Set 3 pezzi semisfere in materiale plastico.  
Set 3 pcs plastic semispheres.

Cod.	Misure - Size
<b>SF 3</b>	Ø 14 - Ø 16 - Ø 18 cm



## STAMPI IN PLASTICA PER TOPOLINI PLASTIC MOULDS FOR MICE

Set di quattro stampi in plastica per la realizzazione di originali monoporzioni o semifreddi a forma di topolino/riccio.  
Set of four plastic moulds to prepare original mono- portions with the shape of a mouse or a hedgehog.

Cod.	Misure - Size
<b>TPSET4</b>	60x80x h30 - 105x75x h40 - 150x120x h51 - 205x150x h67mm



FASCE INOX  
ST. STEEL  
CAKE RINGS



Cod.	H	Misure - Size
1H2X10	20 mm	Ø 100 mm
1H2X12	20 mm	Ø 120 mm
1H2X14	20 mm	Ø 140 mm
1H2X16	20 mm	Ø 160 mm
1H2X18	20 mm	Ø 180 mm
1H2X20	20 mm	Ø 200 mm
1H2X22	20 mm	Ø 220 mm
1H2X24	20 mm	Ø 240 mm
1H2X26	20 mm	Ø 260 mm
1H2X28	20 mm	Ø 280 mm
1H2X30	20 mm	Ø 300 mm



Cod.	H	Misure - Size
4H4X10	40 mm	90x100 mm
4H4X12	40 mm	105x120 mm
4H4X14	40 mm	120x140 mm
4H4X16	40 mm	140x160 mm
4H4X18	40 mm	158x180 mm
4H4X20	40 mm	175x200 mm
4H4X23	40 mm	200x230 mm
4H4X25	40 mm	220x250 mm

Cod.	H	Misure - Size
4H5X10	50 mm	90x100 mm
4H5X12	50 mm	105x120 mm
4H5X14	50 mm	125x140 mm
4H5X16	50 mm	140x160 mm
4H5X18	50 mm	158x180 mm
4H5X20	50 mm	175x200 mm
4H5X23	50 mm	200x230 mm
4H5X25	50 mm	220x250 mm



Cod.	H	Misure - Size
1H4X10	40 mm	Ø 100 mm
1H5X10	50 mm	Ø 100 mm
1H4X12	40 mm	Ø 120 mm
1H5X12	50 mm	Ø 120 mm
1H4X14	40 mm	Ø 140 mm
1H5X14	50 mm	Ø 140 mm
1H4X16	40 mm	Ø 160 mm
1H5X16	50 mm	Ø 160 mm
1H4X18	40 mm	Ø 180 mm
1H5X18	50 mm	Ø 180 mm
1H4X20	40 mm	Ø 200 mm

Cod.	H	Misure - Size
1H5X20	50 mm	Ø 200 mm
1H4X22	40 mm	Ø 220 mm
1H5X22	50 mm	Ø 220 mm
1H4X24	40 mm	Ø 240 mm
1H5X24	50 mm	Ø 240 mm
1H4X26	40 mm	Ø 260 mm
1H5X26	50 mm	Ø 260 mm
1H4X28	40 mm	Ø 280 mm
1H5X28	50 mm	Ø 280 mm
1H4X30	40 mm	Ø 300 mm
1H5X30	50 mm	Ø 300 mm

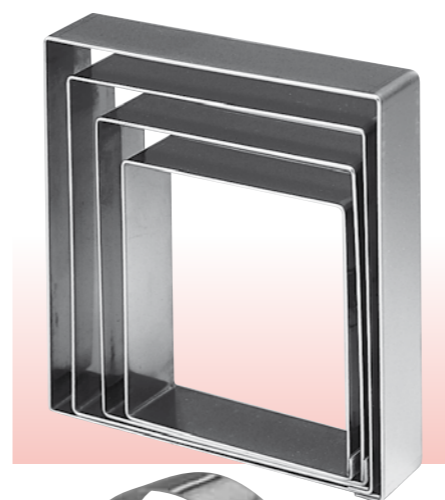

Cod.	H	Misure - Size
5H4X10	40 mm	102x102 mm
5H4X12	40 mm	122x122 mm
5H4X14	40 mm	142x142 mm
5H4X16	40 mm	162x162 mm
5H4X18	40 mm	182x182 mm
5H4X20	40 mm	202x202 mm
5H4X22	40 mm	222x222 mm
5H4X24	40 mm	242x242 mm
5H4X26	40 mm	262x262 mm
5H4X28	40 mm	282x282 mm
5H4X30	40 mm	302x302 mm

Cod.	H	Misure - Size
5H5X10	50 mm	102x102 mm
5H5X12	50 mm	122x122 mm
5H5X14	50 mm	143x143 mm
5H5X16	50 mm	163x163 mm
5H5X18	50 mm	183x183 mm
5H5X20	50 mm	202x202 mm
5H5X22	50 mm	222x222 mm
5H5X24	50 mm	243x243 mm
5H5X26	50 mm	262x262 mm
5H5X28	50 mm	283x283 mm
5H5X30	50 mm	300x300 mm

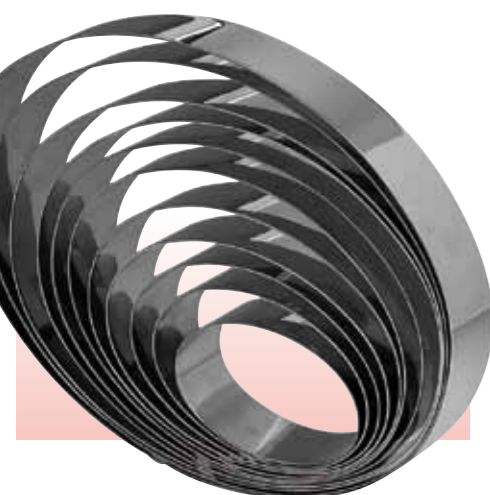

Cod.	H	Misure - Size
2H4X10	40 mm	115x85 mm
2H4X12	40 mm	135x100 mm
2H4X14	40 mm	160x120 mm
2H4X16	40 mm	185x135 mm
2H4X18	40 mm	205x155 mm
2H4X20	40 mm	225x175 mm
2H4X22	40 mm	253x190 mm
2H4X24	40 mm	270x210 mm
2H4X26	40 mm	300x220 mm
2H4X28	40 mm	320x250 mm
2H4X30	40 mm	345x260 mm

Cod.	H	Misure - Size
2H5X10	50 mm	115x85 mm
2H5X12	50 mm	135x100 mm
2H5X14	50 mm	160x120 mm
2H5X16	50 mm	185x135 mm
2H5X18	50 mm	205x155 mm
2H5X20	50 mm	235x165 mm
2H5X22	50 mm	253x190 mm
2H5X24	50 mm	275x200 mm
2H5X26	50 mm	300x220 mm
2H5X28	50 mm	315x250 mm
2H5X30	50 mm	335x270 mm



Cod.	H	Misure - Size
7H4X10	40 mm	115x115 mm
7H4X12	40 mm	135x130 mm
7H4X14	40 mm	160x150 mm
7H4X16	40 mm	175x165 mm
7H4X18	40 mm	200x185 mm
7H4X20	40 mm	220x200 mm
7H4X22	40 mm	235x215 mm
7H4X24	40 mm	250x245 mm
7H4X26	40 mm	245x265 mm
7H4X28	40 mm	285x285 mm

Cod.	H	Misure - Size
7H5X10	50 mm	115x115 mm
7H5X12	50 mm	140x130 mm
7H5X14	50 mm	160x150 mm
7H5X16	50 mm	175x165 mm
7H5X18	50 mm	185x200 mm
7H5X20	50 mm	213x205 mm
7H5X22	50 mm	235x210 mm
7H5X24	50 mm	260x240 mm
7H5X26	50 mm	283x255 mm
7H5X28	50 mm	300x278 mm

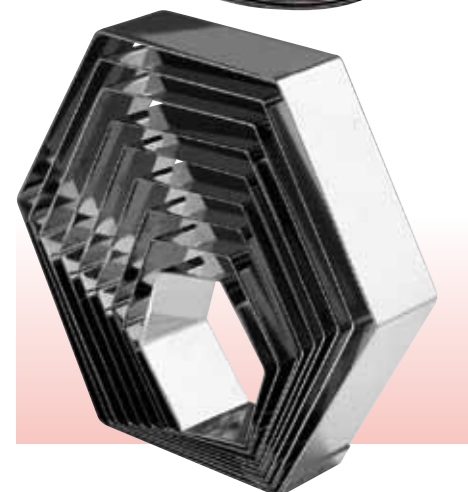

Cod.	H	Misure - Size
3H4X10	40 mm	175x200 mm
3H4X11	40 mm	195x220 mm
3H4X12	40 mm	210x240 mm
3H4X13	40 mm	235x255 mm
3H4X14	40 mm	245x280 mm
3H4X5	40 mm	90x100 mm
3H4X6	40 mm	125x140 mm
3H4X7	40 mm	120x140 mm
3H4X8	40 mm	140x160 mm
3H4X9	40 mm	160x180 mm

Cod.	H	Misure - Size
3H5X10	50 mm	175x200 mm
3H5X11	50 mm	195x220 mm
3H5X12	50 mm	210x240 mm
3H5X13	50 mm	225x260 mm
3H5X14	50 mm	245x280 mm
3H5X5	50 mm	90x100 mm
3H5X6	50 mm	106x120 mm
3H5X7	50 mm	120x140 mm
3H5X8	50 mm	140x160 mm
3H5X9	50 mm	160x180 mm

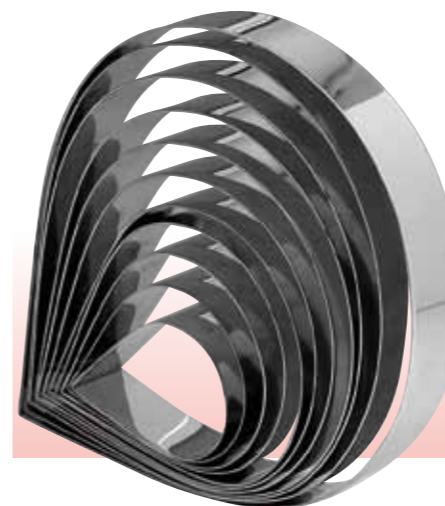

Cod.	H	Misure - Size
8H4X10	40 mm	130x82 mm
8H4X12	40 mm	155x100 mm
8H4X14	40 mm	175x115 mm
8H4X16	40 mm	205x127 mm
8H4X18	40 mm	225x146 mm
8H4X20	40 mm	250x165 mm
8H4X22	40 mm	270x180 mm
8H4X24	40 mm	300x196 mm
8H4X26	40 mm	325x210 mm
8H4X28	40 mm	330x255 mm
8H4X30	40 mm	355x270 mm

Cod.	H	Misure - Size
8H5X10	50 mm	125x85 mm
8H5X12	50 mm	153x97 mm
8H5X14	50 mm	180x115 mm
8H5X16	50 mm	180x165 mm
8H5X18	50 mm	230x145 mm
8H5X20	50 mm	250x162 mm
8H5X22	50 mm	275x176 mm
8H5X24	50 mm	300x192 mm
8H5X26	50 mm	325x210 mm
8H5X28	50 mm	350x225 mm
8H5X30	50 mm	372x245 mm



Cod.	H	Misure - Size
9H4X10	40 mm	138x102 mm
9H4X12	40 mm	170x105 mm
9H4X14	40 mm	192x145 mm
9H4X16	40 mm	215x165 mm
9H4X18	40 mm	235x180 mm
9H4X20	40 mm	255x190 mm
9H4X22	40 mm	295x220 mm
9H4X24	40 mm	312x240 mm
9H4X26	40 mm	345x240 mm
9H4X28	40 mm	375x265 mm

Cod.	H	Misure - Size
9H5X10	50 mm	135x103 mm
9H5X12	50 mm	160x125 mm
9H5X14	50 mm	190x145 mm
9H5X16	50 mm	215x165 mm
9H5X18	50 mm	235x180 mm
9H5X20	50 mm	255x193 mm
9H5X22	50 mm	295x215 mm
9H5X24	50 mm	315x235 mm
9H5X26	50 mm	335x250 mm
9H5X28	50 mm	375x270 mm

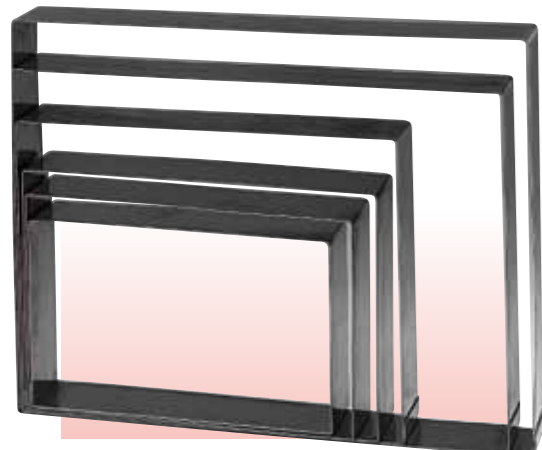

Cod.	H	Misure - Size
11H4L24	40 mm	243x142 mm
11H4L26	40 mm	263x164 mm
11H4L28	40 mm	282x183 mm
11H4L30	40 mm	302x222 mm
11H4L38	40 mm	382x262 mm
11H4L40	40 mm	403x320 mm

Cod.	H	Misure - Size
11H5L24	50 mm	242x142 mm
11H5L26	50 mm	262x164 mm
11H5L28	50 mm	285x184 mm
11H5L30	50 mm	305x223 mm
11H5L38	50 mm	382x265 mm
11H5L40	50 mm	403x302 mm



Cod.	H	Misure - Size
12H4X10	40 mm	90x90 mm
12H4X12	40 mm	106x106 mm
12H4X14	40 mm	130x130 mm
12H4X16	40 mm	150x150 mm
12H4X18	40 mm	175x175 mm
12H4X20	40 mm	193x193 mm
12H4X22	40 mm	217x217 mm
12H4X24	40 mm	237x237 mm
12H4X26	40 mm	257x257 mm
12H4X28	40 mm	275x275 mm
12H4X30	40 mm	300x300 mm

Cod.	H	Misure - Size
12H5X10	50 mm	90x90 mm
12H5X12	50 mm	108x108 mm
12H5X14	50 mm	130x130 mm
12H5X16	50 mm	150x150 mm
12H5X18	50 mm	176x176 mm
12H5X20	50 mm	194x194 mm
12H5X22	50 mm	220x220 mm
12H5X24	50 mm	236x236 mm
12H5X26	50 mm	250x250 mm
12H5X28	50 mm	276x276 mm
12H5X30	50 mm	297x297 mm



Cod.	H	Misure - Size
13H4X15	40 mm	150x65 mm
13H4X23	40 mm	220x95 mm
13H4X30	40 mm	320x125 mm



Cod.	H	Misure - Size
14H4X16	40 mm	158x125 mm
14H4X20	40 mm	210x165 mm
14H4X24	40 mm	240x190 mm
14H4X30	40 mm	300x235 mm



Cod.	H	Misure - Size
15H4X25	40 mm	250x140 mm
15H4X30	40 mm	300x160 mm
15H4X34	40 mm	340x180 mm

## TELAIO IN ACCIAIO ST. STEEL FRAME

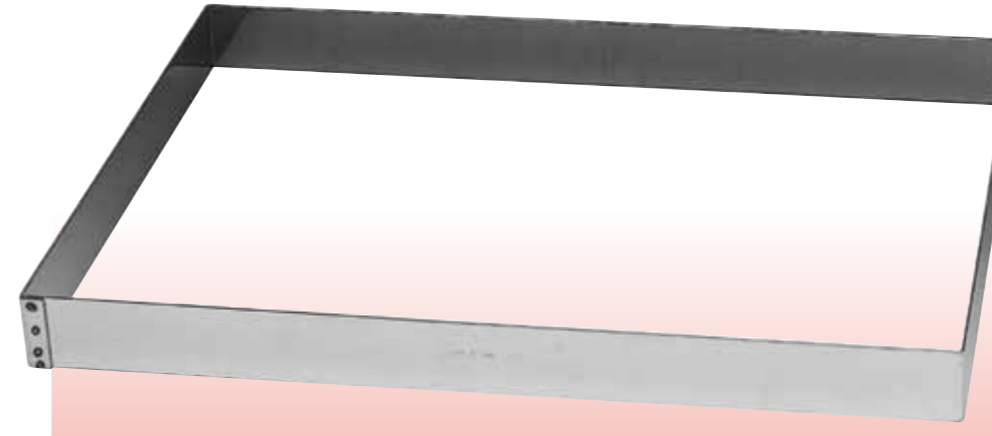

Cod.	H	Misure - Size
RETH4	40 mm	380 x 580 mm
RETH5	50 mm	380 x 580 mm

## TELAIO ESTENDIBILE IN ACCIAIO ST. STEEL EXTENDABLE FRAME

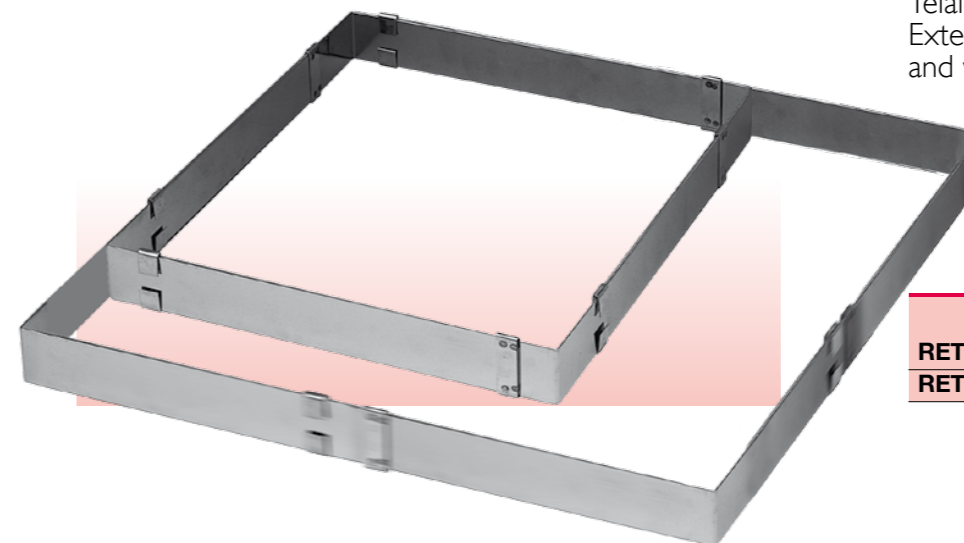

Telaio regolabile in lunghezza ed in larghezza.  
Extendable st. steel frame, length and width adjustable.

Cod.	H	Mis. - Size MIN	Mis. - Size MAX
RETSPECIAL 1	40 mm	305 x 305 mm	570 x 560 mm
RETSPECIAL 2	50 mm	305 x 305 mm	570 x 560 mm

## DECORAZIONE CORTECCIA BARK DECORATION



Strisce decoro in plastica.  
Plastic strips for decoration.

Cod.	Misure - Size	Pack
CORT 4	800x40 mm	10 pcs
CORT 5	800x50 mm	8 pcs

## STAMPI PER GELATINE JELLY MOULDS

Stampi per gelatine, in puro silicone alimentare, per la realizzazione di gelatine alla frutta, fondenti, ecc.  
Telaio in plastica.

Silicone moulds for fruit jelly, fondant, etc.  
Plastic frame.

Dimensione placca  
Moulds size 18x33,5 cm

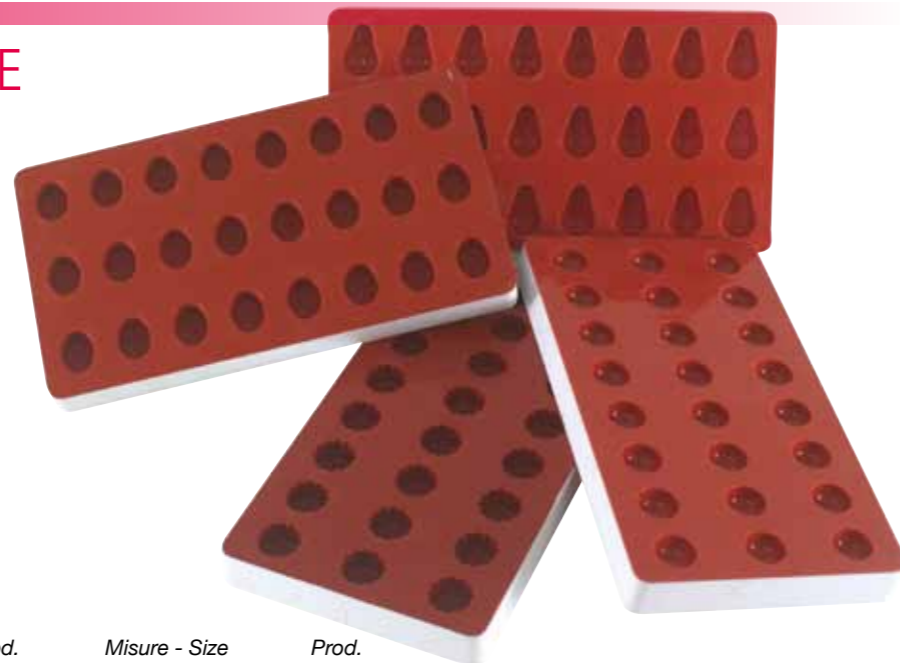

Forma - Shape	Cod.	Misure - Size	Prod.
 Fetta Arancio / Orangeslice	<b>SG 01</b>	45 x 18 x 15	3 x 8 = 24
 Pera / Pear	<b>SG 02</b>	40 x 26 x 15	3 x 8 = 24
 Cuore / Heart	<b>SG 03</b>	34 x 30 x 18	3 x 8 = 24
 Mezzasfera / Halfsphere	<b>SG 04</b>	Ø27 x h13,5	3 x 8 = 24
 Bon Bon / Pastille	<b>SG 05</b>	Ø30 x h11	3 x 8 = 24
 Mora / Berry	<b>SG 06</b>	Ø30 x h24	3 x 8 = 24
 Ananas / Pineapple	<b>SG 07</b>	33 x 23 x 18	3 x 8 = 24
 Fragola / Strawberry	<b>SG 08</b>	36 x 30 x 20	3 x 8 = 24
 Pesca / Peach	<b>SG 09</b>	35 x 25 x 20	3 x 8 = 24



Colare la gelatina su ogni cavità con lo speciale colino inox.  
Cod. COLINO  
Una volta raffreddato il prodotto, rovesciare lo stampo sopra una bacinella contenente zucchero.  
Pour the jelly in each single mould using the special piston funnel.  
Cod. COLINO  
Once cooled, turn the mould upside down in a sugar basin.

 Visualizza i tutorial sul nostro canale YouTube  
Watch the step-by-step on our YouTube channel

## ESPOSITORE IN METALLO METAL DISPLAY

Cod.	Misure - Size
<b>ESPOSITORE</b>	95x55 h210cm



## TORTIERE IN SILICONE SILICONE CAKE MOULDS

Per dolci, crostate, torte salate, pizze, torte, budini, brioches, sformati, sorbetti, gelati, mousse di frutta o verdure... Si puliscono semplicemente sotto un getto di acqua calda, con l'aiuto di una spugna o in lavastoviglie.  
Per una manutenzione ottimale spolverizzare lo stampo con farina, cacao o zucchero a velo prima dell'uso.  
For cakes, jam tarts, savoury flans, pizzas, puddings, buns, sorbets, fruit or vegetable mousses... They can be easily cleaned with a sponge and hot water or in the dishwasher.  
We advise dusting the mould with flour, cocoa powder or icing sugar before using it.

Cod. SFT201/Y	Misure - Size Ø260 h40 mm Ø10,24 h1,57"	Cod. SFT202/Y	Misure - Size Ø260 h50 mm Ø10,24 h1,97"	Cod. SFT203/Y	Misure - Size 280x200 h40 mm 11,02x7,87 h1,57"
Cod. SFT204/Y	Misure - Size 290x200 h 60 mm 11,42x7,87 h2,36"	Cod. SFT210/Y	Misure - Size 220x218 h30 mm 8,66x8,58 h1,18"		

Cod. SFT220/Y	Misure - Size Ø220 h45 mm Ø8,66 h1,77"	Cod. SFT224/Y	Misure - Size Ø240 h 60 mm Ø9,45 h2,36"	Cod. SFT228/Y	Misure - Size Ø280 h20 mm Ø11,02 h 0,79"
Cod. SFT250/Y	Misure - Size Ø220 h110 mm Ø8,66 h4,33"	Cod. SFT251/Y	Misure - Size Ø220 h100 mm Ø8,66 h3,94"		

Cod. SFT252/Y	Misure - Size Ø260 h 70 mm Ø10,24 h3,76"	Cod. SFT300/Y	Misure - Size 280x220 h40 mm 11,02x8,66 h1,57"	Cod. SFT302/Y	Misure - Size 280x215 h50 mm 11,02x8,47 h1,97"
Cod. SFT514/Y	Misure - Size Ø140 h50 mm Ø5,60 h2,00"	Cod. SFT522/Y	Misure - Size Ø220 h 80 mm Ø8,66 h3,15"		

Cod. SFT600/Y	Misure - Size Ø240 h100 mm Ø9,45 h3,94"	Cod. SFT722/Y	Misure - Size Ø220 h100 mm Ø8,66 h3,94"	Cod. SFT726/Y	Misure - Size Ø260 h 80 mm Ø10,24 h3,15"
Cod. SFT730/Y	Misure - Size 300x145 h 80 mm 11,80x5,70 h3,15"	Cod. SFT326/Y	Misure - Size 240x105 h 65 mm 9,45x4,13 h2,56"		

Cod. SFT118/Y	Misure - Size Ø180 h40 mm Ø7,09 h1,57"	Cod. SFT124/Y	Misure - Size Ø240 h42 mm Ø9,45 h1,65"
Cod. SFT120/Y	Misure - Size Ø200 h40 mm Ø7,87 h1,57"	Cod. SFT126/Y	Misure - Size Ø260 h45 mm Ø10,24 h1,77"
Cod. SFT122/Y	Misure - Size Ø220 h42 mm Ø8,66 h1,65"	Cod. SFT128/Y	Misure - Size Ø280 h47 mm Ø11,02 h1,85"

Cod. SFT424/Y	Misure - Size Ø240 h30 mm Ø9,45 h1,18"	
Cod. SFT426/Y	Misure - Size Ø260 h30 mm Ø10,24 h1,18"	
Cod. SFT428/Y	Misure - Size Ø280 h 30 mm Ø11,02 h 1,18"	

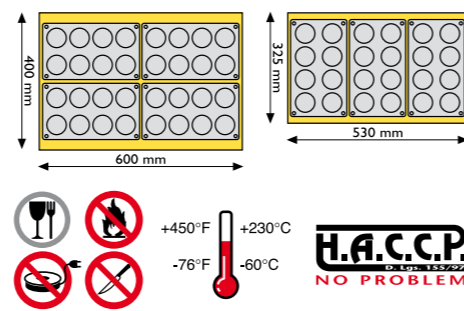

**Non usare l'anello in microonde.  
The ring cannot be used in the microwave.**

Gli stampi sono forniti di un anello brevettato, con le stesse caratteristiche dello stampo, che rende il suo bordo rigido. Assicurarsi che l'anello sia ben fissato allo stampo prima di utilizzarlo e toglierlo prima dell'operazione di sfornatura. In dotazione con tutti gli UNIFLEX. Può andare in forno e/o in abbattitore. Identifica i siliconi Martellato, detentriche del brevetto.

The moulds are provided with a patented ring, with the same characteristics of the moulds, to make the edge stiff. Make sure that the ring is well fixed to the mould before using it and remove it before turning out. It is enclosed in every UNIFLEX. It can be baked and/or frozen. It distinguishes Martellato silicone moulds, the holder of the patent.

## MONOPORZIONE IN SILICONE SILICONE MONOPORTIONS MOULDS

Gli stampi in silicone antiaderente SILICONFLEX permettono di superare definitivamente i problemi legati alla preparazione dei prodotti da pasticceria e ristorazione. SILICONFLEX moulds are made of non-stick silicone. They solve all the problems related to the preparation of pastry and food in general.



Cod. SFT061

Misure - Size	Ø75 h40 mm
2x3 fig.	Ø2,75 h1,57"

Siliconflex è disponibile senza imballo o in confezione da 1 pezzo: confezione da 1 pezzo es. cod. SF 010 senza imballo es. cod. SF 010/N

Siliconflex is available without package or in box of 1 unit: package of 1 mould ex. cod. SF 010 unpacked ex. cod. SF 010/N



Cod. SF001	Misure - Size Ø80 h40 mm 5 fig. Ø3,15 h1,57"	Cod. SF002	Misure - Size Ø70 h35 mm 6 fig. Ø2,75 h1,37"	Cod. SF003	Misure - Size Ø60 h30 mm 6 fig. Ø2,35 h1,18"
Cod. SF004	Misure - Size Ø50 h25 mm 8 fig. Ø1,96 h 0,98"	Cod. SF005	Misure - Size Ø40 h20 mm 15 fig. Ø1,57 h 0,78"		

Cod. SF006	Misure - Size Ø30 h15mm 24 fig. Ø1,18 h 0,59"	Cod. SF007	Misure - Size 71x71 h40mm 6 fig. 2,79x2,79 h1,57"	Cod. SF008	Misure - Size 36x36 h22 mm 15 fig. 1,41x1,41 h 0,86"
Cod. SF009	Misure - Size Ø34 h16 mm 24 fig. Ø1,33 h 0,63"	Cod. SF010	Misure - Size Ø41 h12 mm 18 fig. Ø1,61 h 0,47"		

Cod. SF006	Misure - Size Ø30 h15mm 24 fig. Ø1,18 h 0,59"	Cod. SF007	Misure - Size 71x71 h40mm 6 fig. 2,79x2,79 h1,57"	Cod. SF008	Misure - Size 36x36 h22 mm 15 fig. 1,41x1,41 h 0,86"
Cod. SF009	Misure - Size Ø34 h16 mm 24 fig. Ø1,33 h 0,63"	Cod. SF010	Misure - Size Ø41 h12 mm 18 fig. Ø1,61 h 0,47"		

Cod. SF006	Misure - Size Ø30 h15mm 24 fig. Ø1,18 h 0,59"	Cod. SF007	Misure - Size 71x71 h40mm 6 fig. 2,79x2,79 h1,57"	Cod. SF008	Misure - Size 36x36 h22 mm 15 fig. 1,41x1,41 h 0,86"
Cod. SF009	Misure - Size Ø34 h16 mm 24 fig. Ø1,33 h 0,63"	Cod. SF010	Misure - Size Ø41 h12 mm 18 fig. Ø1,61 h 0,47"		



Cod.	Misure - Size	Cod.	Misure - Size	Cod.	Misure - Size	Cod.	Misure - Size	Cod.	Misure - Size
<b>SF011</b>	Ø65 h21 mm 8 fig. Ø2,55 h 0,82"	<b>SF012</b>	Ø72 h23 mm 6 fig. Ø2,83 h 0,90"	<b>SF013</b>	Ø45 h10 mm 15 fig. Ø1,77 h 0,39"	<b>SF014</b>	Ø50 h15 mm 15 fig. Ø1,96 h 0,59"	<b>SF015</b>	Ø60 h17 mm 8 fig. Ø2,35 h 0,68"



Cod.	Misure - Size	Cod.	Misure - Size	Cod.	Misure - Size	Cod.	Misure - Size	Cod.	Misure - Size
<b>SF016</b>	Ø70 h20 mm 6 fig. Ø2,75 h 0,78"	<b>SF017</b>	55x33 h20mm 16 fig. 2,16x1,29 h 0,78"	<b>SF018</b>	70x50 h20 mm 9 fig. 2,75x1,96 h 0,78"	<b>SF019</b>	Ø35 h38 mm 15 fig. Ø1,37 h1,49"	<b>SF020</b>	Ø45 h48 mm 11 fig. Ø1,77 h1,88"



Cod.	Misure - Size	Cod.	Misure - Size	Cod.	Misure - Size	Cod.	Misure - Size	Cod.	Misure - Size
<b>SF021</b>	Ø55 h 60 mm 8 fig. Ø2,16 h2,35"	<b>SF022</b>	Ø51 h28 mm 11 fig. Ø2,00 h1,10"	<b>SF023</b>	Ø69 h35 mm 6 fig. Ø2,71 h1,37"	<b>SF024</b>	Ø81 h32 mm 5 fig. Ø3,18 h1,26"	<b>SF025</b>	49x26 h11mm 20 fig. 1,92x1,02 h 0,43"



Cod.	Misure - Size	Cod.	Misure - Size	Cod.	Misure - Size	Cod.	Misure - Size	Cod.	Misure - Size
<b>SF026</b>	79x29 h30mm 12 fig. 3,10x1,14 h1,78"	<b>SF027</b>	Ø40 h20 mm 15 fig. Ø1,57 h 0,78"	<b>SF028</b>	Ø60 h35 mm 8 fig. Ø2,35 h1,37"	<b>SF029</b>	Ø60 h12 mm 8 fig. Ø2,35 h 0,47"	<b>SF030</b>	Ø35 h5 mm 24 fig. Ø1,37 h 0,20"



Cod.	Misure - Size	Cod.	Misure - Size	Cod.	Misure - Size	Cod.	Misure - Size	Cod.	Misure - Size
<b>SF031</b>	44x34 h10mm 15 fig. 1,73x1,33 h 0,39"	<b>SF032</b>	68x45 h17 mm 9 fig. 2,67x1,77 h 0,67"	<b>SF033</b>	Ø35 h35 mm 18 fig. Ø1,37 h1,37"	<b>SF034</b>	Ø79 h37 mm 6 fig. Ø3,10 h1,45"	<b>SF035</b>	Ø79 h30 mm 6 fig. Ø3,10 h1,18"



Cod.	Misure - Size	Cod.	Misure - Size	Cod.	Misure - Size	Cod.	Misure - Size	Cod.	Misure - Size
<b>SF036</b>	Ø65 h40 mm 6 fig. Ø2,55 h1,57"	<b>SF037</b>	Ø38 h26 mm 15 fig. Ø1,49 h1,02"	<b>SF038</b>	72x30 h15mm 12 fig. 2,83x1,18 h 0,59"	<b>SF039</b>	100x44 h15mm 9 fig. 3,92x1,73 h 0,59"	<b>SF040</b>	Ø60 h35 mm 8 fig. Ø2,35 h1,37"



Cod.	Misure - Size	Cod.	Misure - Size	Cod.	Misure - Size	Cod.	Misure - Size	Cod.	Misure - Size
<b>SF041</b>	102x73 h36mm 5 fig. 4,00x2,86 h1,41"	<b>SF042</b>	Ø103 h20 mm 3 fig. Ø4,04 h 0,78"	<b>SF043</b>	Ø40 h13 mm 15 fig. Ø1,57 h 0,51"	<b>SF044</b>	Ø50 h14 mm 15 fig. Ø1,96 h 0,55"	<b>SF045</b>	Ø60 h17 mm 8 fig. Ø2,35 h 0,67"



Cod.	Misure - Size	Cod.	Misure - Size	Cod.	Misure - Size	Cod.	Misure - Size	Cod.	Misure - Size
<b>SF046</b>	Ø70 h17 mm 6 fig. Ø2,75 h 0,67"	<b>SF047</b>	Ø80 h18 mm 6 fig. Ø3,14 h 0,71"	<b>SF048</b>	Ø35 h23 mm 18 fig. Ø1,37 h 0,90"	<b>SF049</b>	Ø68 h45 mm 6 fig. Ø2,67 h1,77"	<b>SF050</b>	Ø55 h50 mm 8 fig. Ø2,16 h1,96"



Cod.	Misure - Size	Cod.	Misure - Size	Cod.	Misure - Size	Cod.	Misure - Size	Cod.	Misure - Size
<b>SF051</b>	Ø57 h57 mm 8 fig. Ø2,24 h2,24"	<b>SF052</b>	Ø75 h 60 mm 6 fig. Ø2,95 h2,36"	<b>SF053</b>	Ø60 h20 mm 6 fig. Ø2,36 h 0,79"	<b>SF054</b>	95x45 h12 mm 7 fig. 3,74x0,27 h 0,47"	<b>SF055</b>	75x55 h35 mm 8 fig. 2,95x2,16 h1,38"



Cod.	Misure - Size	Cod.	Misure - Size	Cod.	Misure - Size	Cod.	Misure - Size	Cod.	Misure - Size
<b>SF056</b>	Ø70 h28 mm 6 fig. Ø2,75 h1,10"	<b>SF057</b>	Ø55 h36 mm 8 fig. Ø2,16 h1,42"	<b>SF058</b>	Ø70 h36 mm 6 fig. Ø2,75 h1,42"	<b>SF059</b>	Ø45 h45 mm 18 fig. Ø1,77 h1,77"	<b>SF060</b>	50x25 h20mm 20 fig. 1,95x1 h 0,78"



Cod.	Descr.
<b>CUTTER 50</b>	per/for SF014
<b>CUTTER 80</b>	per/for SF047

\*disponibile tagliapasta  
\*dough cutter available

Con i taglia pasta su misura la preparazione dei vostri prodotti sarà ancora più facile e rapida.  
Preparing your best products will be even easier and faster using our dough cutters.

Sostegno in acciaio inox per sgocciolare i Silicoflex.  
Stainless steel support to leave the Silicoflex to dry.

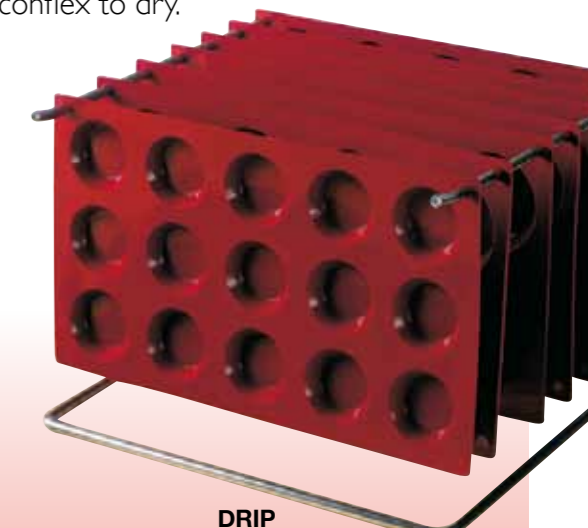

DRIP

## TAPPETI PER MACARONS MACARONS BAKING SHEETS

Cod.	Misure - Size	Prod.	Ø
<b>30TM6001R</b>	60x40cm	70 gusci/shells	Ø40mm
<b>30TM3001R</b>	30x40cm	34 gusci/shells	Ø40mm

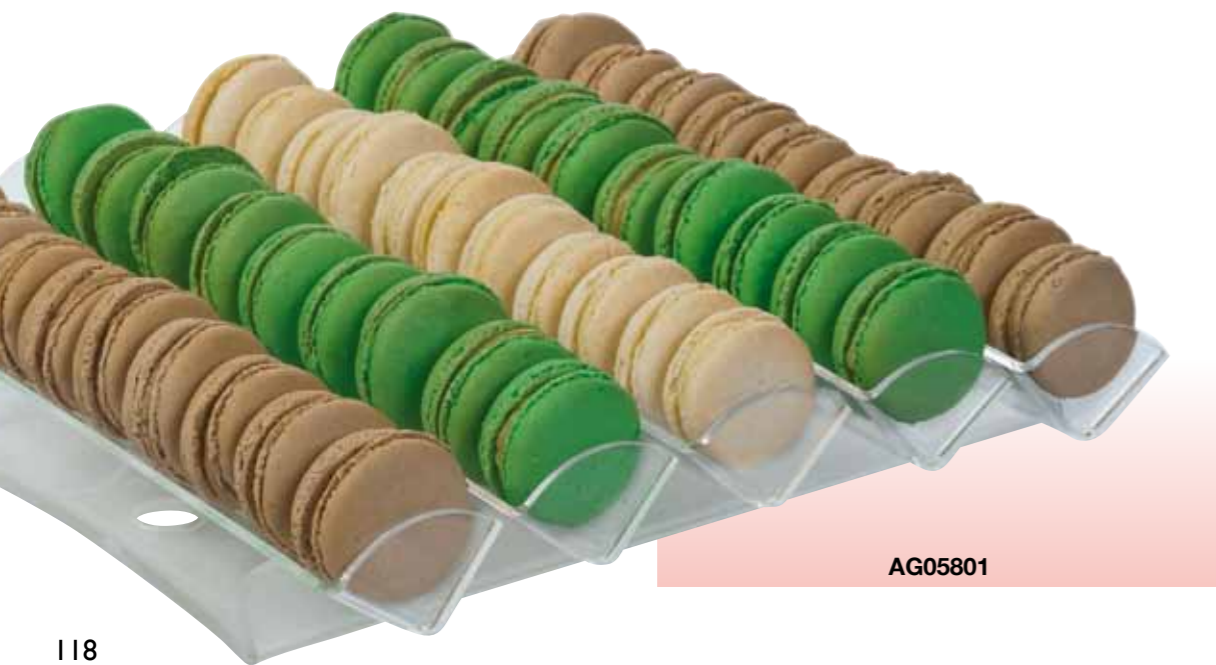

AG05801

## PORTA MACARONS MACARONS HOLDER

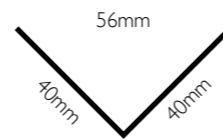

Cod.	Misure - Size	x Macaron	Colore - Colors
<b>AG05700</b>	46x33 h 14,5 cm	Ø45 mm	Bianco - White
<b>AG05701</b>	46x33 h 14,5 cm	Ø45 mm	Transp.



Cod.	Misure - Size	x Macaron	Colore - Colors
<b>AG05600</b>	27x33 h 14,5 cm	Ø45 mm	Bianco - White
<b>AG05601</b>	27x33 h 14,5 cm	Ø45 mm	Transp.

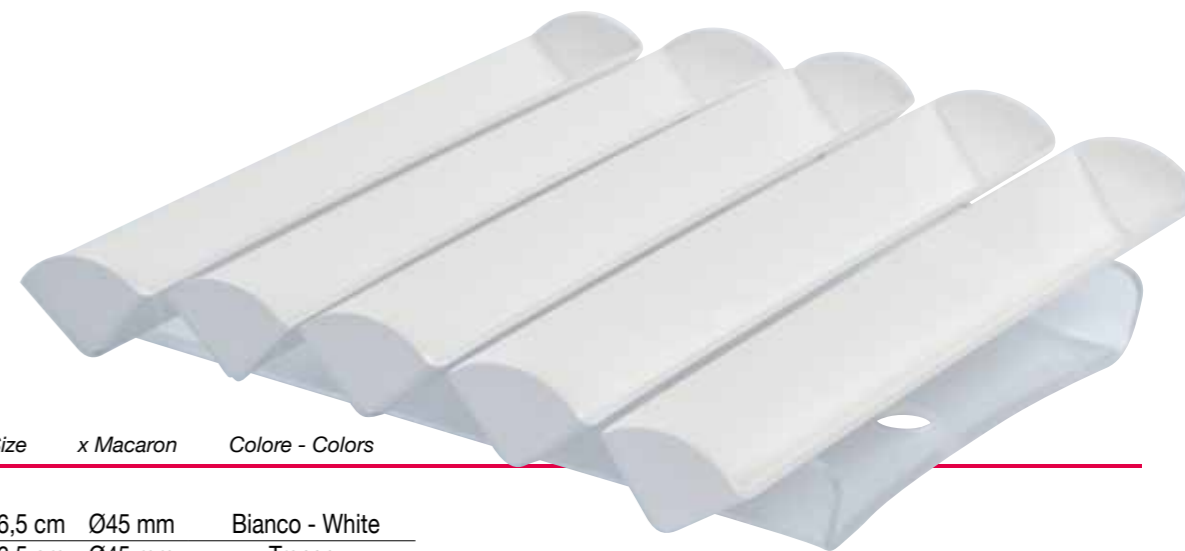

Cod.	Misure - Size	x Macaron	Colore - Colors
<b>AG05800</b>	31,5x32,5 h 6,5 cm	Ø45 mm	Bianco - White
<b>AG05801</b>	31,5x32,5 h 6,5 cm	Ø45 mm	Transp.